

REV.	SPECIFICATION	ECN NO.	APPD.

Material:

Cage: C7701-H, 50u" Nickel Plated.
 Clip: Stainless Steel.
 Light Pipe: Polycarbonate, Color Clear.
***RoHS Compliant**

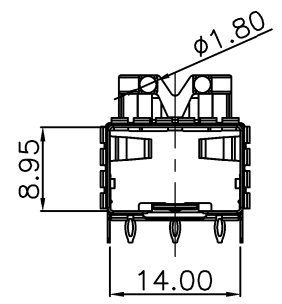
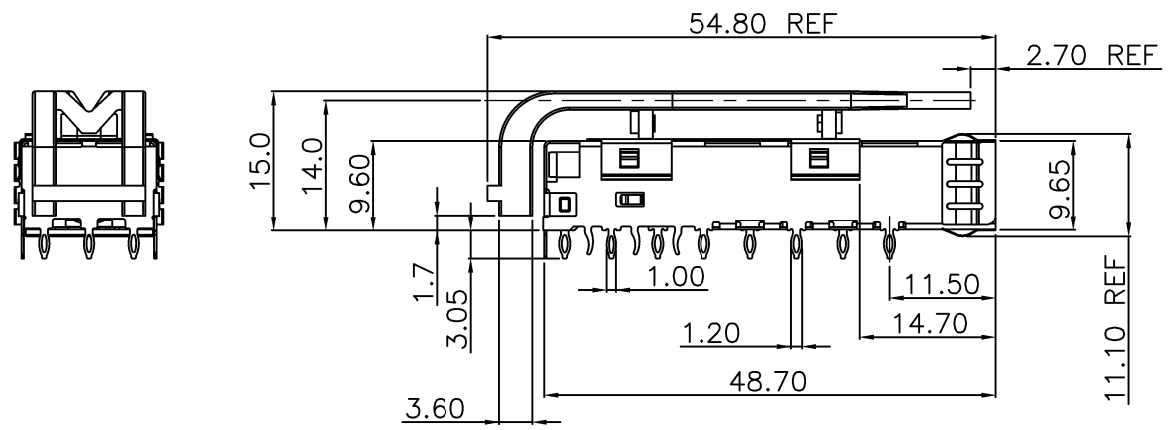
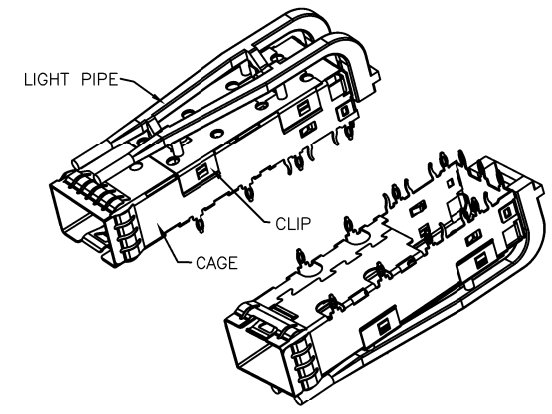
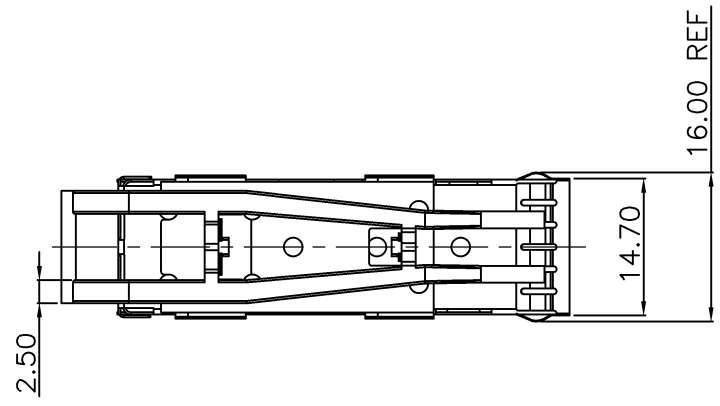

Tolerances .xx = ±0.25 .xxx = ±0.15	Dwg. No.	8951D00013		Title: 8951-A Series SFP+ Cage, R/A, Metal Shield Press Fit Type With Spring ① 665	 OUPIIN ELECTRONIC(KUNSHAN) CO., LTD. P/N: 8951-A1PP1A			
	Projection							
	Unit	mm	Scale		1:1	SHEET	1/3	Ver. No.
Drawn By	Jerry 07/06'20							

REV.	SPECIFICATION	ECN NO.	APPD.

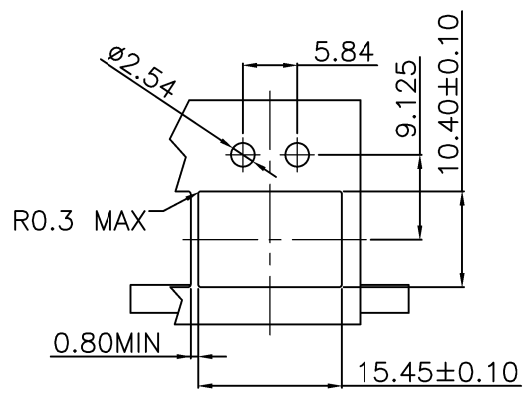

BEZEL
 RECOMMENDED PANEL CUTOUT AND PC BOARD
 PANEL POSITION AND THICKNESS 0.8–2.6

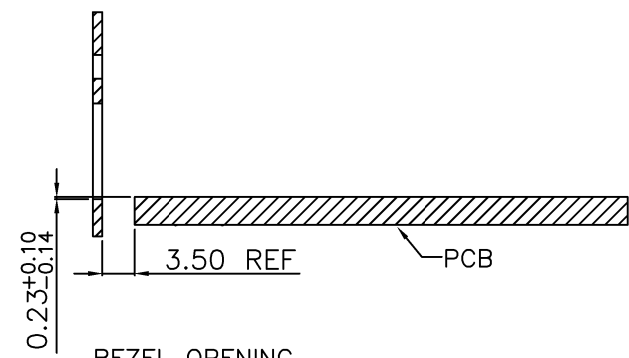

BEZEL OPENING
 BELOW TOP OF PCB

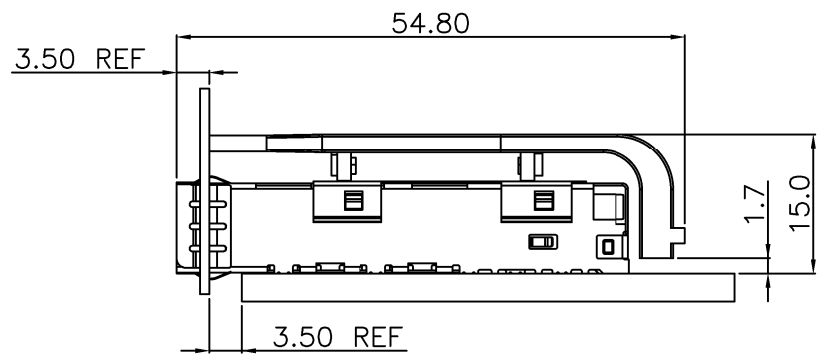
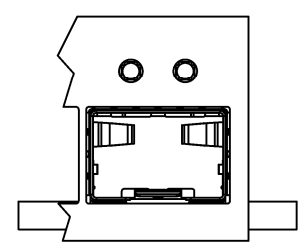

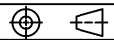
Tolerances .xx = ±0.25 .xxx = ±0.15	Dwg. No.	8951D00013		Title: 8951-A Series SFP+ Cage, R/A, Metal Shield Press Fit Type With Spring ① 665	 OUPIIN ELECTRONIC(KUNSHAN) CO., LTD. P/N: 8951-A1PP1A			
	Projection							
	Unit	mm	Scale		1:1	Drawn By	Jerry 07/06'20	

REV.	SPECIFICATION	ECN NO.	APPD.

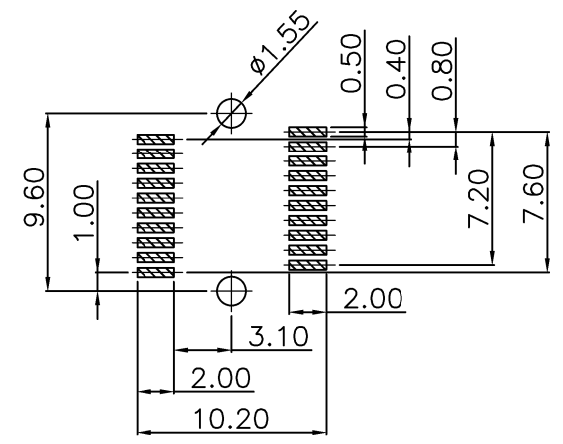
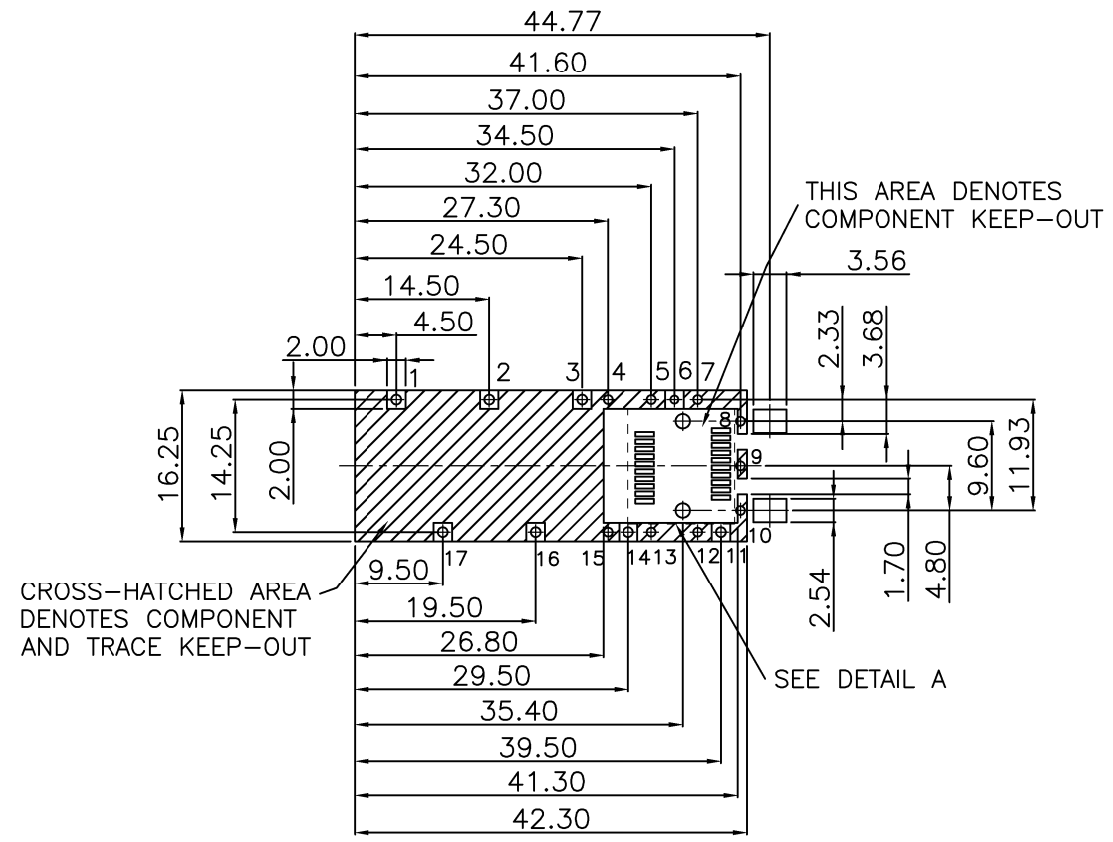

DETAIL A

P.C.Board Layout
TOLERANCE: ±0.05

NOTE:
1,2,3,11,14,16,17= ϕ 1.05mm
4,5,7,8,9,10,12,13,15= ϕ 0.95mm
6= ϕ 0.85mm.

Tolerances .xx = ±0.25 .xxx = ±0.15	Dwg. No.	8951D00013		Title: 8951-A Series SFP+ Cage, R/A, Metal Shield Press Fit Type With Spring ① 665	 OUPIIN ELECTRONIC(KUNSHAN) CO., LTD. P/N: 8951-A1PP1A		
	Projection					SHEET	3/3
	Unit	mm	Scale			1:1	Ver. No.
Drawn By	Jerry 07/06'20						