

歐品電子(昆山)有限公司

OUPIIN ELECTRONIC(KUNSHAN) CO.,LTD.

PACKAGING SPECIFICATION (包裝作業規範)

CONFIDENTIAL TOP SECRET

SPEC.NO.(規範編號) Q2141SPP-124		APPLICABLE CUSTOMER (適用客戶) ALL		APPLICABLE PRODUCT (適用產品) 2141-1XxxGxxSA		PAGE 1/6	REV. J
						PACKAGING CATEGORY (包裝方式)	TRAY PLATE PACKING

REVISION HISTORY (修訂履歷)

REV.	ECN NO	PAGE (頁次)							
		1	2	3	4				
J		Change SPP as standard. (改為標準SPP.)							

DIVISION (事業單位)	Product Development (產品開發課)	APPROVED (核准)	CHECKED (審核)	PREPARED (制表)	Gao Juan 04/16'08
-----------------	-----------------------------	---------------	--------------	---------------	-------------------

歐品電子(昆山)有限公司

OUPHIN ELECTRONIC(KUNSHAN) CO.,LTD.

PACKAGING SPECIFICATION (包裝作業規範)

CONFIDENTIAL TOP SECRET

SPEC.NO.(規範編號) Q2141SPP-124

PAGE 2/6 REV. J

PACKING OPERATION DIAGRAM & INSTRUCTION (包裝作業圖示及說明)

REMARK (備注)

Laying Product Diagram:
(產品擺放圖示)

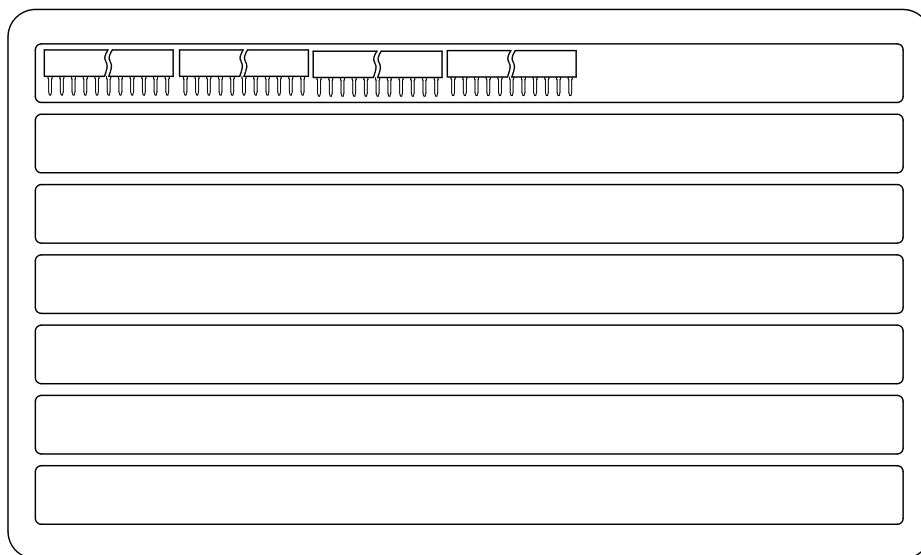

一.PVC Plate Packing Mode:
(PVC盤包裝方式)

(1).CT-0.9 Box: PVC-2141-01 60 PCS.

(CT-0.9 規格的紙箱放PVC-2141-01盤 60 PCS)

(2).Put product in each trough fully as shown in diagram.
(產品在盤子中擺放方式如圖所示)

(3).After filling each trough with product fully,cover it
with transparent upper cover PVC-2141-01 1PCS。
(每盤放滿產品後,加蓋透明上蓋 PVC-2141-01 1PCS)

(4).Stack the XX PVC plates filled with product, put them in
the paper box in which has been put waterproof bag.
(將放滿產品的XX個PVC盤疊起,裝入防水袋放入紙箱內)

歐品電子(昆山)有限公司

OUPIIN ELECTRONIC(KUNSHAN) CO.,LTD.

PACKAGING SPECIFICATION (包裝作業規範)

<input checked="" type="checkbox"/> CONFIDENTIAL		<input type="checkbox"/> TOP SECRET	
PAGE	3/6	REV.	J

SPEC.NO.(規範編號) Q2141SPP-124

PACKING OPERATION DIAGRAM & INSTRUCTION (包裝作業圖示及說明)	REMARK (備注)
---	-------------

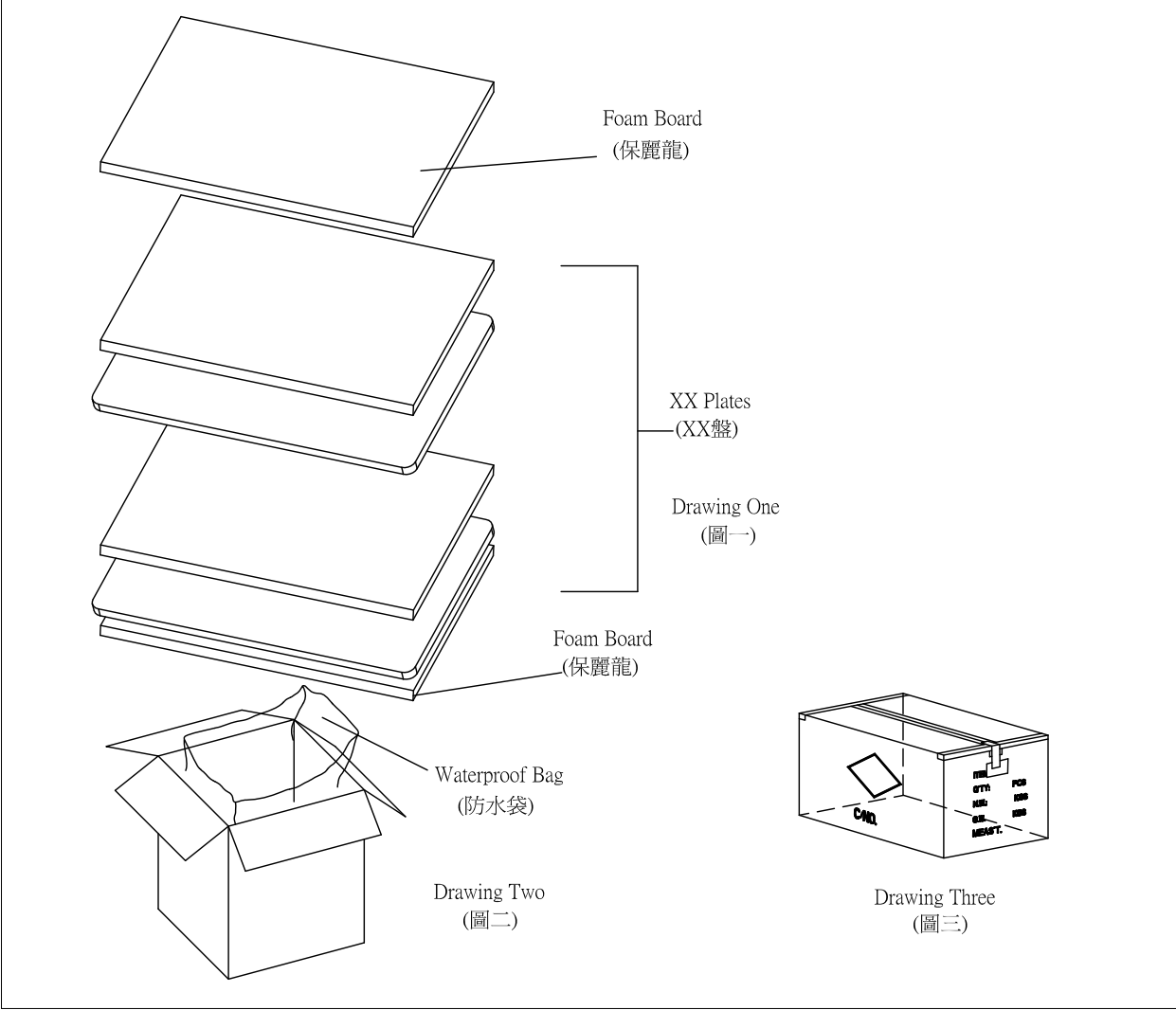

一. Outer Box Packing Mode:
(外箱包裝方式)

- (1). Paper box 0.9 standard 1 PCS, as shown in drawing Two.
(紙箱 0.9 規格 1 PCS, 如(圖二)所示)
- (2). Put one Foam Board in the upper and lower of the paper box, 2 PCS in all, as shown in drawing One.
(每箱上下各放一塊保麗龍, 共 2 PCS, 如(圖一)所示)
- (3). Put 1 PCS waterproof in the paper box, as shown in drawing Two.
(紙箱內側放入防水袋 1 PCS, 如(圖二)所示)
- (4). Piled the XX packing plates packed up in the waterproof.
(將放滿產品的 XX 個 PVC 盤疊起, 裝入防水袋內)
- (5). Seal the waterproof bag, then put the Foam Board 1 PCS on the bag.
(Put 1 PCS Foam Board at the right and left side in the paper box if it is necessary.)
(封上防水袋, 然後放上第二塊保麗龍薄板)
(必要時, 在紙箱的左右兩側各放一塊保麗龍)
- (6). Seal the surface of the outer box, as shown in drawing Three.
(將外箱上層封口, 如(圖三)所示)

The form on the right and flank side of the box must be filled correctly and clearly, take actual testing weight as the standard of each box gross weight.
外箱之正麥和側麥所要填寫之項目要填寫正確, 清晰, 每箱之毛重應以實測重量為準.

歐品電子(昆山)有限公司

OUPIIN ELECTRONIC(KUNSHAN) CO.,LTD.

PACKAGING SPECIFICATION (包裝作業規範)

CONFIDENTIAL TOP SECRET

SPEC.NO.(規範編號)		Q2141SPP-124					PAGE:			4/6	REV.	J
PACKING MATERIAL (包裝材料)			PRODUCT P/N	CT NO.	PACKING N.W.	PACKING QUANTITY (包裝數量)			WEIGHT (重量) kg			
MATERIAL NAME (材料名稱)	PART NO. (料號)	Q'TY	(產品料號)	(紙箱規格)	(包材重量)	PCS/TRAY	TRAY/BOX	PCS/BOX	N.W./PCS	N.W./BOX	G.W./BOX	
PAPER BOXES (紙箱)	CT-0.9	1	2141-1X02GxxSA	CT-0.9	7.77	798	60	47880	0.000057	2.74	10.50	
Packing Box (包裝盒)	PVC-2141-01	----	2141-1X03GxxSA	CT-0.9	7.77	532	60	31920	0.000086	2.74	10.50	
			2141-1X04GxxSA	CT-0.9	7.77	392	60	23520	0.000114	2.69	10.46	
			2141-1X05GxxSA	CT-0.9	7.77	308	60	18480	0.000143	2.64	10.41	
Packing Box Cover (包裝盒蓋子)	PVC-2141-01	----	2141-1X06GxxSA	CT-0.9	7.77	266	60	15960	0.000171	2.74	10.50	
			2141-1X07GxxSA	CT-0.9	7.77	224	60	13440	0.000200	2.69	10.46	
			2141-1X08GxxSA	CT-0.9	7.77	196	60	11760	0.000229	2.69	10.45	
WATERPROOF BAG (防水袋)	PE 100*70	1	2141-1X09GxxSA	CT-0.9	7.77	168	60	10080	0.000257	2.59	10.36	
			2141-1X10GxxSA	CT-0.9	7.77	154	60	9240	0.000286	2.64	10.41	
			2141-1X11GxxSA	CT-0.9	7.77	140	60	8400	0.000314	2.64	10.41	
Foam (保麗龍)	-----	2	2141-1X12GxxSA	CT-0.9	7.77	126	60	7560	0.000343	2.59	10.36	
			2141-1X13GxxSA	CT-0.9	7.77	112	60	6720	0.000371	2.50	10.26	
			2141-1X14GxxSA	CT-0.9	7.77	112	60	6720	0.000400	2.69	10.45	
DRYING AGENT (干燥劑)	-----	3	2141-1X15GxxSA	CT-0.9	7.77	98	60	5880	0.000429	2.52	10.29	
			2141-1X16GxxSA	CT-0.9	7.77	98	60	5880	0.000457	2.69	10.46	
			2141-1X17GxxSA	CT-0.9	7.77	84	60	5040	0.000486	2.45	10.22	
			2141-1X18GxxSA	CT-0.9	7.77	84	60	5040	0.000514	2.59	10.36	
			2141-1X19GxxSA	CT-0.9	7.77	84	60	5040	0.000543	2.74	10.50	

1.NOTE:

(注意)

When the finished products have been made,take the actual weight as the standard of gross weight in each box.

(成品出貨時,每箱之毛重應以實測重量為準)

When the finished products have been made,stick the proper designation list on the box according to product demand.

(成品出貨時,依據出貨要求貼上相對應的標籤單)

歐品電子(昆山)有限公司

OUPIIN ELECTRONIC(KUNSHAN) CO.,LTD.

PACKAGING SPECIFICATION (包裝作業規範)

CONFIDENTIAL TOP SECRET

SPEC.NO.(規範編號)		Q2141SPP-124								PAGE: 5/6		REV. J	
PACKING MATERIAL (包裝材料)			PRODUCT P/N	CT NO.	PACKING N.W.	PACKING QUANTITY (包裝數量)			WEIGHT (重量) kg				
MATERIAL NAME (材料名稱)	PART NO. (料號)	Q'TY	(產品料號)	(紙箱規格)	(包材重量)	PCS/TRAY	TRAY/BOX	PCS/BOX	N.W./PCS	N.W./BOX	G.W./BOX		
PAPER BOXES (紙箱)	CT-0.9	1	2141-1X20GxxSA	CT-0.9	7.77	70	60	4200	0.000571	2.40	10.17		
Packing Box (包裝盒)	PVC-2141-01	----	2141-1X21GxxSA	CT-0.9	7.77	70	60	4200	0.000600	2.52	10.29		
			2141-1X22GxxSA	CT-0.9	7.77	70	60	4200	0.000629	2.64	10.41		
			2141-1X23GxxSA	CT-0.9	7.77	56	60	3360	0.000657	2.21	9.98		
Packing Box Cover (包裝盒蓋子)	PVC-2141-01	----	2141-1X24GxxSA	CT-0.9	7.77	56	60	3360	0.000686	2.30	10.07		
			2141-1X25GxxSA	CT-0.9	7.77	56	60	3360	0.000714	2.40	10.17		
			2141-1X26GxxSA	CT-0.9	7.77	56	60	3360	0.000743	2.50	10.26		
WATERPROOF BAG (防水袋)	PE 100*70	1	2141-1X27GxxSA	CT-0.9	7.77	56	60	3360	0.000771	2.59	10.36		
			2141-1X28GxxSA	CT-0.9	7.77	56	60	3360	0.000800	2.69	10.46		
			2141-1X29GxxSA	CT-0.9	7.77	42	60	2520	0.000829	2.09	9.86		
Foam (保麗龍)	-----	2	2141-1X30GxxSA	CT-0.9	7.77	42	60	2520	0.000857	2.16	9.93		
			2141-1X31GxxSA	CT-0.9	7.77	42	60	2520	0.000886	2.23	10.00		
			2141-1X32GxxSA	CT-0.9	7.77	42	60	2520	0.000914	2.30	10.07		
DRYING AGENT (干燥劑)	-----	3	2141-1X33GxxSA	CT-0.9	7.77	42	60	2520	0.000943	2.38	10.14		
			2141-1X34GxxSA	CT-0.9	7.77	42	60	2520	0.000971	2.45	10.22		
			2141-1X35GxxSA	CT-0.9	7.77	42	60	2520	0.001000	2.52	10.29		
			2141-1X36GxxSA	CT-0.9	7.77	42	60	2520	0.001029	2.59	10.36		
			2141-1X37GxxSA	CT-0.9	7.77	42	60	2520	0.001057	2.66	10.43		

1.NOTE:

(注意)

When the finished products have been made,take the actual weight as the standard of gross weight in each box.

(成品出貨時,每箱之毛重應以實測重量為準)

When the finished products have been made,stick the proper designation list on the box according to product demand.

(成品出貨時,依據出貨要求貼上相對應的標籤單)

歐品電子(昆山)有限公司

OUPIIN ELECTRONIC(KUNSHAN) CO.,LTD.

PACKAGING SPECIFICATION (包裝作業規範)

CONFIDENTIAL TOP SECRET

SPEC.NO.(規範編號)		Q2141SPP-124					PAGE:		6/6	REV.	J
PACKING MATERIAL (包裝材料)			PRODUCT P/N	CT NO.	PACKING N.W.	PACKING QUANTITY (包裝數量)			WEIGHT (重量) kg		
MATERIAL NAME (材料名稱)	PART NO. (料號)	Q'TY	(產品料號)	(紙箱規格)	(包材重量)	PCS/TRAY	TRAY/BOX	PCS/BOX	N.W./PCS	N.W./BOX	G.W./BOX
PAPER BOXES (紙箱)	CT-0.9	1	2141-1X38GxxSA	CT-0.9	7.77	42	60	2520	0.001086	2.74	10.50
Packing Box (包裝盒)	PVC-2141-01	----	2141-1X39GxxSA	CT-0.9	7.77	28	60	1680	0.001114	1.87	9.64
			2141-1X40GxxSA	CT-0.9	7.77	28	60	1680	0.001143	1.92	9.69
Packing Box Cover (包裝盒蓋子)	PVC-2141-01	----									
WATERPROOF BAG (防水袋)	PE 100*70	1									
Foam (保麗龍)	-----	2									
DRYING AGENT (干燥劑)	-----	3									

1.NOTE:

(注意)

When the finished products have been made,take the actual weight as the standard of gross weight in each box.

(成品出貨時,每箱之毛重應以實測重量為準)

When the finished products have been made,stick the proper designation list on the box according to product demand.

(成品出貨時,依據出貨要求貼上相對應的標籤單)