

歐品電子(昆山)有限公司

OUPIIN ELECTRONIC(KUNSHAN) CO.,LTD.

PACKAGING SPECIFICATION (包裝作業規範)

SPEC.NO.(規範編號) Q2241SPP-125

■ CONFIDENTIAL □ TOP SECRET			
PAGE	2/6	REV.	J

PACKING OPERATION DIAGRAM & INSTRUCTION (包裝作業圖示及說明)

REMARK (備注)

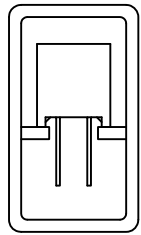

Drawing One: Product Installing Mode
(圖一產品裝入方式)

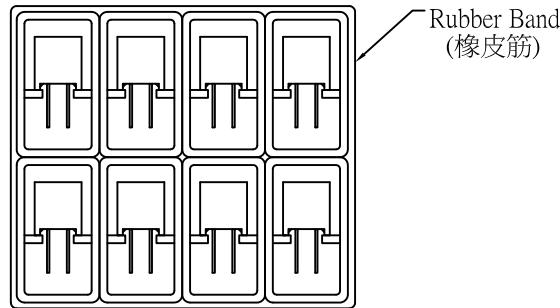

Drawing Two: Each Bundle Eight Tube
(圖二: 每8管為1捆)

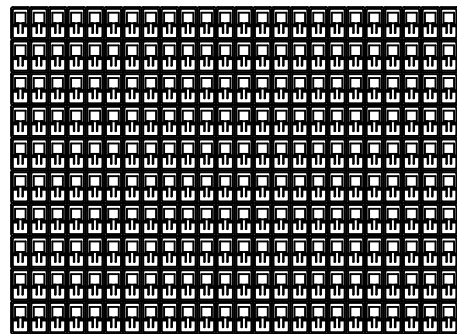

Drawing Three: 6 bundles are put on the eachth floor. Divide 5 layers to put, a box amounts to 30 bundles, amounts to 240 tubes

((圖3)每層放6捆。分5層放入,一盒共30捆,共240管)
Disposing schematic diagram of Tube in the inner box, for reference.
(管在內盒的擺放示意圖,供參考)

一.Inner box packing mode: (內盒包裝方式)

- (1).Each tube packing mode:Stuff one end of tube with stopper, stuff the other end of the tube after load into definite quality of product, as shown in drawing One.And stuffing in stopper,the end of the stopper must be level with the tube mouth, can't be shown.
(每管包裝方式:用塞子塞住管子一頭,放入一定數量產品後,塞住另一頭,裝入方式如(圖一)所示.且塞子塞入後,末端要和管口平齊,不可外露.)
- (2).Every 8 tubes products are divided into 2 layers, placing manner: Such as (Fig. 2) Show, from both ends to, 50mm of calibre, every twine with the intersection of 1PCS and rubber band 2 line fixed.
(每8管產品分2層,放置方式:如(圖2)所示,兩頭離管口50mm處,各用1PCS橡皮筋纏2道固定.)
- (3).A box and 30 bundles, divide 5 layers to put, 6 bundles are put on the eachth floor. Amounts to 240 tubes. Such as (Fig. three) Show
(一盒30捆,分5層放入,每層放6捆。共240管。如(圖三)所示)

歐品電子(昆山)有限公司

OUPIIN ELECTRONIC(KUNSHAN) CO.,LTD.

PACKAGING SPECIFICATION (包裝作業規範)

<input checked="" type="checkbox"/> CONFIDENTIAL		<input type="checkbox"/> TOP SECRET	
PAGE	3/6	REV.	J

SPEC.NO.(規範編號) Q2241SPP-125

PACKING OPERATION DIAGRAM & INSTRUCTION (包裝作業圖示及說明)

REMARK (備注)

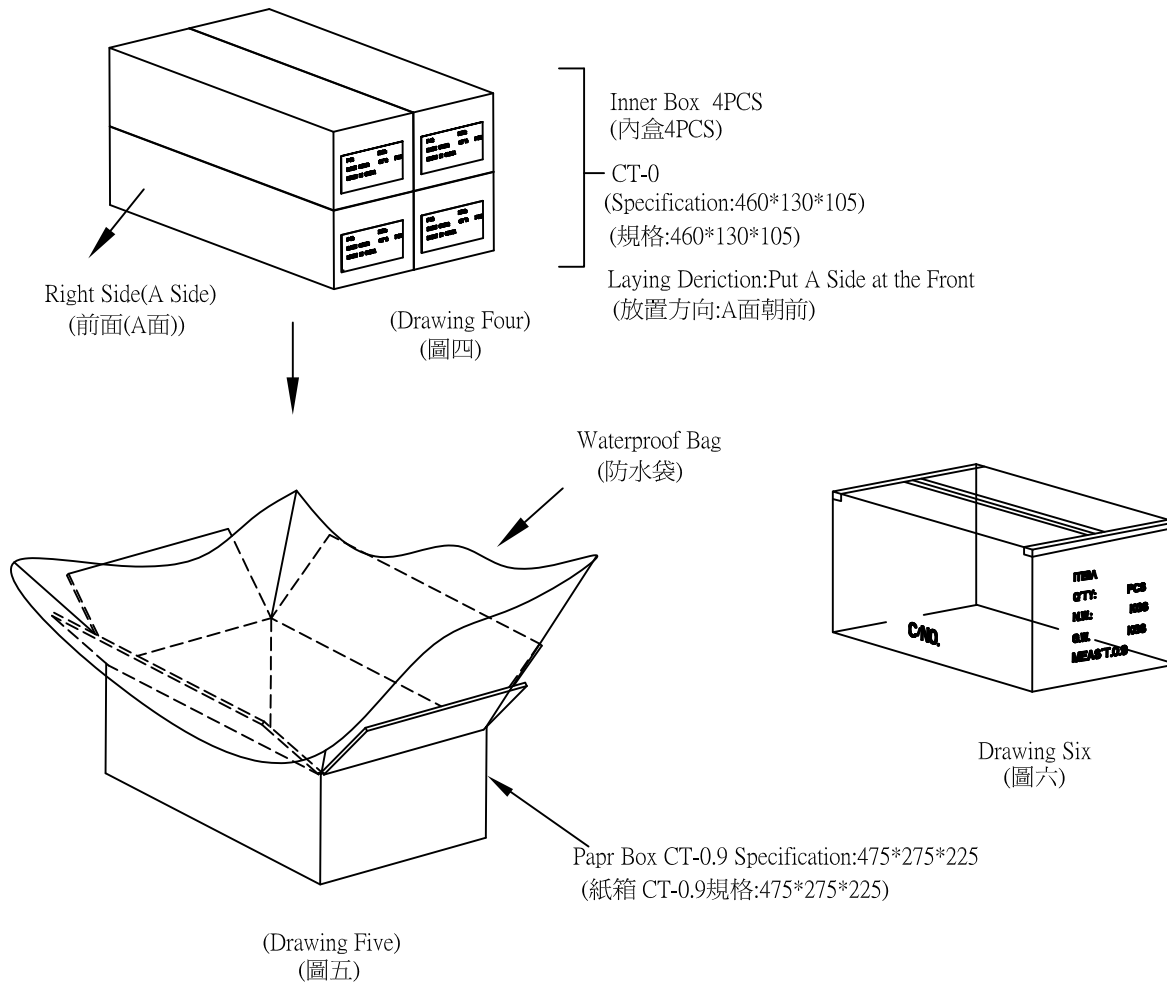

二.Outer box packing mode: (外箱包裝方式)

- (1).Paper box CT-0.9 Standart 1 PCS.
(紙箱CT-0.9規格 1 PCS.)
- (2).Put waterproof bag 1 PCS in the paper box.
(紙箱內側放入防水袋 1 PCS.)
- (3).Put 4PCS inner box filled with product in the waterproof bag.
(于防水袋內放入4PCS裝滿產品之內盒.)
- (4).Laying mode of the four inner boxes is that A side in front side., the laying mode of the four inner boxes must in one direction.
(四個內盒的放置方式為1面朝前放置,四內盒放置方向須一致.)
- (5).The detailed specification of inner box is shown in page two.
(內盒之詳細包裝規範如第2頁.)
- (6).After laying inner boxes, tie the waterproof bag tightly.Seal the surface of the outer box.(Drawing Six)
(放好內盒，扎緊防水袋。將外箱上層封口。(圖六))

The form on the right and flank side of the bo must be filled correctly and clearly, take actual testing weight as the standard of every box gross weight.

(外箱之正麥和側麥所要填寫之項目要填寫正確,清晰,每箱之毛重應以實測重量為準.)

歐品電子(昆山)有限公司

OUPIIN ELECTRONIC(KUNSHAN) CO.,LTD.

PACKAGING SPECIFICATION (包裝作業規範)

CONFIDENTIAL TOP SECRET

SPEC.NO.(規範編號)		Q2241SPP-125										PAGE: 4/6		REV. J	
PACKING MATERIAL (包裝材料)			PRODUCT P/N	PACKING N.W.	PACKING QUANTITY (包裝數量)					WEIGHT (重量) kg					
MATERIAL NAME (材料名稱)	PART NO. (料號)	Q'TY	(產品料號)	(包材重量)	PCS/TUBE	TUBE/INNER BOX	PCS/INNER BOX	INNER BOX/BOX	PCS/BOX	N.W./PCS	N.W./BOX	G.W./BOX			
PAPER BOXES (紙箱)	CT-0.9	1	2241-2X03G(C)xxSU	13.76	100	240	24000	4	96000	0.00008	8.06	21.82			
PACKING INNER BOX (內紙箱)	CT-0	4	2241-2X04G(C)xxSU	13.76	77	240	18480	4	73920	0.00011	8.28	22.04			
			2241-2X05G(C)xxSU	13.76	63	240	15120	4	60480	0.00014	8.47	22.23			
			2241-2X06G(C)xxSU	13.76	52	240	12480	4	49920	0.00017	8.39	22.15			
TUBE (管子)	TUBE-2241	960	2241-2X07G(C)xxSU	13.76	45	240	10800	4	43200	0.00020	8.47	22.23			
			2241-2X08G(C)xxSU	13.76	40	240	9600	4	38400	0.00022	8.60	22.36			
			2241-2X09G(C)xxSU	13.76	36	240	8640	4	34560	0.00025	8.71	22.47			
TUBE PLUG (塞子)	-----	1920	2241-2X10G(C)xxSU	13.76	32	240	7680	4	30720	0.00028	8.60	22.36			
			2241-2X11G(C)xxSU	13.76	29	240	6960	4	27840	0.00031	8.57	22.33			
			2241-2X12G(C)xxSU	13.76	27	240	6480	4	25920	0.00034	8.71	22.47			
WATERPROFF BAG (防水袋)	PE100*70	1	2241-2X13G(C)xxSU	13.76	25	240	6000	4	24000	0.00036	8.74	22.50			
			2241-2X14G(C)xxSU	13.76	23	240	5520	4	22080	0.00039	8.66	22.42			
			2241-2X15G(C)xxSU	13.76	22	240	5280	4	21120	0.00042	8.87	22.63			
DRYING AGENT (干燥劑)	-----	3	2241-2X16G(C)xxSU	13.76	20	240	4800	4	19200	0.00045	8.60	22.36			
			2241-2X17G(C)xxSU	13.76	19	240	4560	4	18240	0.00048	8.68	22.44			
RUBBER RIBE (橡皮筋)	-----	240	2241-2X18G(C)xxSU	13.76	18	240	4320	4	17280	0.00050	8.71	22.47			
			2241-2X19G(C)xxSU	13.76	17	240	4080	4	16320	0.00053	8.68	22.44			
			2241-2X20G(C)xxSU	13.76	15	240	3600	4	14400	0.00056	8.06	21.82			

1.NOTE:

(注意)

When the finished products have been made,take the actual weight as the standard of gross weight in each box.

(成品出貨時,每箱之毛重應以實測重量為準)

When the finished products have been made,stick the proper designation list on the box according to product demand.

(成品出貨時,依據出貨要求貼上相對應的標籤單)

歐品電子(昆山)有限公司

OUPIIN ELECTRONIC(KUNSHAN) CO.,LTD.

PACKAGING SPECIFICATION (包裝作業規範)

CONFIDENTIAL TOP SECRET

SPEC.NO.(規範編號)		Q2241SPP-125								PAGE:	5/6	REV.	J
PACKING MATERIAL (包裝材料)			PRODUCT P/N	PACKING N.W.	PACKING QUANTITY (包裝數量)					WEIGHT (重量) kg			
MATERIAL NAME (材料名稱)	PART NO. (料號)	Q'TY	(產品料號)	(包材重量)	PCS/TUBE	TUBE/INNER BOX	PCS/INNER BOX	INNER BOX/BOX	PCS/BOX	N.W./PCS	N.W./BOX	G.W./BOX	
PAPER BOXES (紙箱)	CT-0.9	1	2241-2X21G(C)xxSU	13.76	14	240	3360	4	13440	0.00059	7.90	21.66	
PACKING INNER BOX (內紙箱)	CT-0	4	2241-2X22G(C)xxSU	13.76	14	240	3360	4	13440	0.00062	8.28	22.04	
			2241-2X23G(C)xxSU	13.76	14	240	3360	4	13440	0.00064	8.66	22.42	
			2241-2X24G(C)xxSU	13.76	13	240	3120	4	12480	0.00067	8.39	22.15	
TUBE (管子)	TUBE-2241	960	2241-2X25G(C)xxSU	13.76	13	240	3120	4	12480	0.00070	8.74	22.50	
			2241-2X26G(C)xxSU	13.76	12	240	2880	4	11520	0.00073	8.39	22.15	
			2241-2X27G(C)xxSU	13.76	12	240	2880	4	11520	0.00076	8.71	22.47	
TUBE PLUG (塞子)	-----	1920	2241-2X28G(C)xxSU	13.76	11	240	2640	4	10560	0.00078	8.28	22.04	
			2241-2X29G(C)xxSU	13.76	11	240	2640	4	10560	0.00081	8.57	22.33	
			2241-2X30G(C)xxSU	13.76	11	240	2640	4	10560	0.00084	8.87	22.63	
WATERPROFF BAG (防水袋)	PE100*70	1	2241-2X31G(C)xxSU	13.76	10	240	2400	4	9600	0.00087	8.33	22.09	
			2241-2X32G(C)xxSU	13.76	10	240	2400	4	9600	0.00090	8.60	22.36	
			2241-2X33G(C)xxSU	13.76	10	240	2400	4	9600	0.00092	8.87	22.63	
DRYING AGENT (干燥劑)	-----	3	2241-2X34G(C)xxSU	13.76	9	240	2160	4	8640	0.00095	8.23	21.99	
			2241-2X35G(C)xxSU	13.76	9	240	2160	4	8640	0.00098	8.47	22.23	
RUBBER RIBE (橡皮筋)	-----	240	2241-2X36G(C)xxSU	13.76	9	240	2160	4	8640	0.00101	8.71	22.47	
			2241-2X37G(C)xxSU	13.76	9	240	2160	4	8640	0.00104	8.95	22.71	
			2241-2X38G(C)xxSU	13.76	8	240	1920	4	7680	0.001064	8.17	21.93	

1.NOTE:

(注意)

When the finished products have been made,take the actual weight as the standard of gross weight in each box.

(成品出貨時,每箱之毛重應以實測重量為準)

When the finished products have been made,stick the proper designation list on the box according to product demand.

(成品出貨時,依據出貨要求貼上相對應的標籤單)

歐品電子(昆山)有限公司

OUPIIN ELECTRONIC(KUNSHAN) CO.,LTD.

PACKAGING SPECIFICATION (包裝作業規範)

CONFIDENTIAL TOP SECRET

SPEC.NO.(規範編號)		Q2241SPP-125								PAGE:	6/6	REV.	J
PACKING MATERIAL (包裝材料)			PRODUCT P/N	PACKING N.W.	PACKING QUANTITY (包裝數量)					WEIGHT (重量) kg			
MATERIAL NAME (材料名稱)	PART NO. (料號)	Q'TY	(產品料號)	(包材重量)	PCS/TUBE	TUBE/INNER BOX	PCS/INNER BOX	INNER BOX/BOX	PCS/BOX	N.W./PCS	N.W./BOX	G.W./BOX	
PAPER BOXES (紙箱)	CT-0.9	1	2241-2X39G(C)xxSU	13.76	8	240	1920	4	7680	0.00109	8.39	22.15	
PACKING INNER BOX (內紙箱)	CT-0	4	2241-2X40G(C)xxSU	13.76	8	240	1920	4	7680	0.00112	8.60	22.36	
			2241-2X41G(C)xxSU	13.76	8	240	1920	4	7680	0.00115	8.82	22.58	
			2241-2X42G(C)xxSU	13.76	7	240	1680	4	6720	0.00118	7.90	21.66	
TUBE (管子)	TUBE-2241	960	2241-2X43G(C)xxSU	13.76	7	240	1680	4	6720	0.00120	8.09	21.85	
			2241-2X44G(C)xxSU	13.76	7	240	1680	4	6720	0.00123	8.28	22.04	
			2241-2X45G(C)xxSU	13.76	7	240	1680	4	6720	0.00126	8.47	22.23	
TUBE PLUG (塞子)	-----	1920	2241-2X46G(C)xxSU	13.76	7	240	1680	4	6720	0.00129	8.66	22.42	
			2241-2X47G(C)xxSU	13.76	7	240	1680	4	6720	0.00132	8.84	22.60	
			2241-2X48G(C)xxSU	13.76	6	240	1440	4	5760	0.00134	7.74	21.50	
WATERPROFF BAG (防水袋)	PE100*70	1	2241-2X49G(C)xxSU	13.76	6	240	1440	4	5760	0.00137	7.90	21.66	
			2241-2X50G(C)xxSU	13.76	6	240	1440	4	5760	0.00140	8.06	21.82	
DRYING AGENT (干燥劑)	-----	3											
RUBBER RIBE (橡皮筋)	-----	240											

1.NOTE:

(注意)

When the finished products have been made,take the actual weight as the standard of gross weight in each box.

(成品出貨時,每箱之毛重應以實測重量為準)

When the finished products have been made,stick the proper designation list on the box according to product demand.

(成品出貨時,依據出貨要求貼上相對應的標籤單)