

歐品電子(昆山)有限公司  
 OUPIIN ELECTRONIC(KUNSHAN) CO.,LTD.  
 包裝作業規範  
 PACKAGING SPECIFICATION

CONFIDENTIAL  TOP SECRET

規範編號SPEC.NO. Q9001SPP-311T1

PAGE 1/4 REV. H

適用客戶  
 APPLICABLE  
 CUSTOMER ALL

適用產品  
 APPLICABLE  
 PRODUCT 9001-51151xA

包裝方式  
 PACKAGING  
 CATEGORY TRAY PLATE PACKING

修訂履歷 REVISION HISTORY

REV.	ECN NO	頁次 PAGE								
		1	2	3	4					
D		Change to put method (變更產品防止方式)								
E		Pack a material number in modification (修改包裝盤料號)								
F		Add New material number (新增料號)								
G		Modify the binding way (修改裝訂方式)								
H		Chage Quantity (變更包裝層數)								

事業單位  
 DIVISION (產品開發課)  
 Product Development

核 准  
 APPROVED Peter Zhu

審 核  
 CHECKED

Nita Lu

制 表  
 PREPARED

Martin 06/01'23

歐品電子(昆山)有限公司  
 OUPIIN ELECTRONIC(KUNSHAN) CO.,LTD.

包裝作業規範  
 PACKAGING SPECIFICATION

<input checked="" type="checkbox"/> CONFIDENTIAL	<input type="checkbox"/> TOP SECRET
PAGE	2/4
REV.	H

規範編號SPEC.NO. Q9001SPP-311T1

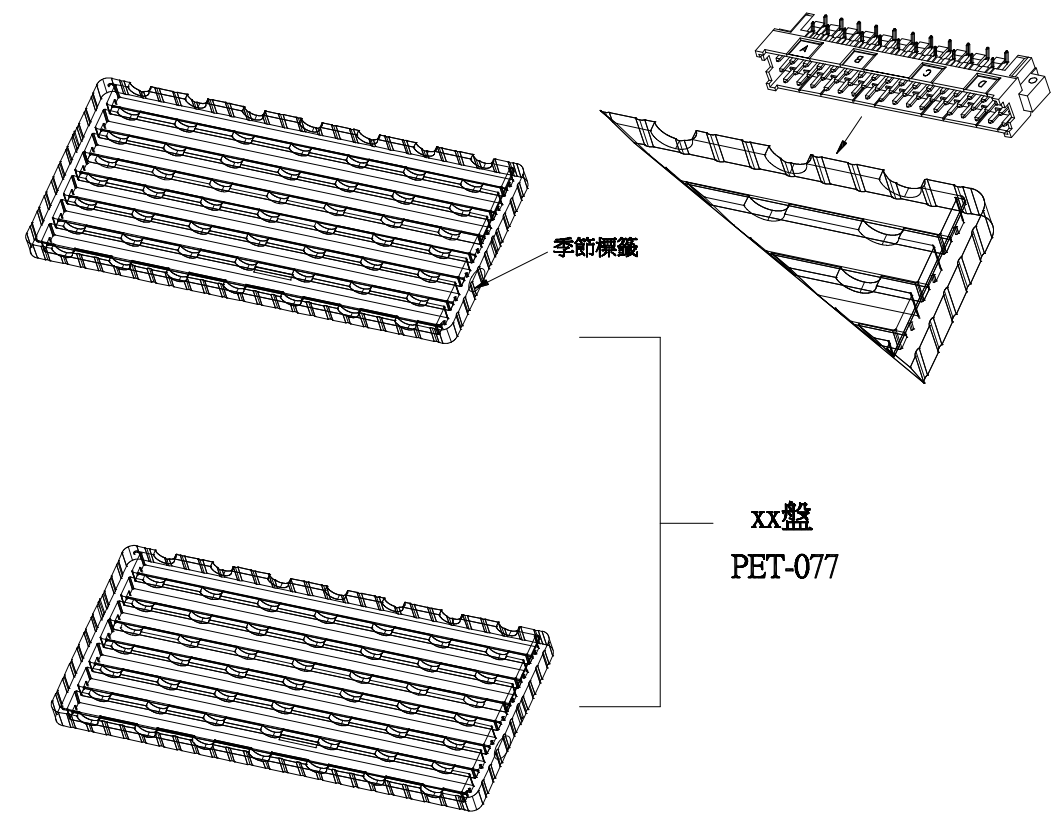
包裝作業圖示及說明 PACKING OPERATION DIAGRAM & INSTRUCTION	備注 REMARK
 <p>季節標籤</p> <p>XX盤 PET-077</p>	<p>一.PET Plate Packing Mode:                  (PET盤包裝方式)</p> <p>(1).CT-1.6 Box:PET-077 18 PCS.</p> <p>(2).Put product in each trough fully as shown in diagram.                  (產品在盤子中擺放方式如圖所示)</p> <p>(3).After filling each trough with product fully,paste the season label 1 PCS cover it with transparent upper cover PVC-073 1PCS。                  (每盤放滿產品後,貼上季節標籤 1PCS,加蓋透明上蓋 PVC-073 1PCS)</p> <p>(4).After each dish with transparent over,together with stapler will cover and the chassis.                  (每盤加蓋透明上蓋後,用訂書機將上蓋與底盤訂在一起)</p> <p>(5).Stack the XX PET plates filled with product, put them in the paper box in which has been put waterproof bag.                  (將放滿產品的XX個PET盤疊起,裝入防水袋放入紙箱內)</p>

歐品電子(昆山)有限公司  
 OUPIIN ELECTRONIC(KUNSHAN) CO.,LTD.

包裝作業規範  
 PACKAGING SPECIFICATION

規範編號SPEC.NO. Q9001SPP-311T1

CONFIDENTIAL TOP SECRET  
 PAGE 3/4 REV. H

包裝作業圖示及說明

PACKING OPERATION DIAGRAM & INSTRUCTION

備注 REMARK

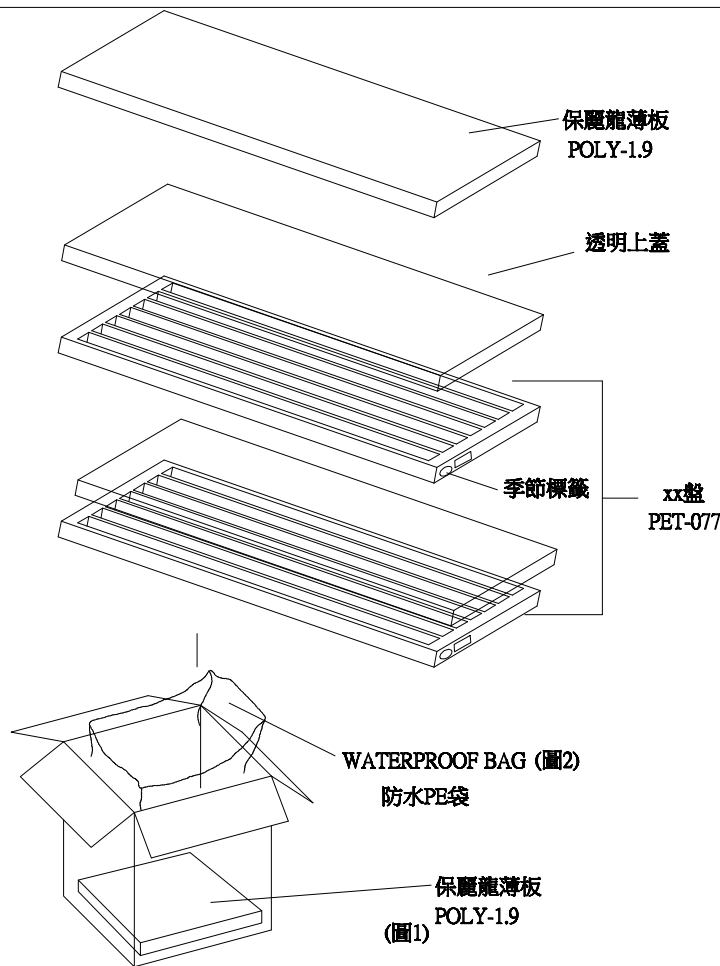

Outer Box Packing Mode:  
 (外箱包裝方式)

- (1).Paper box 1.6 standard 1 PCS,as shown in drawing Two.  
 (紙箱1.6規格 1 PCS.如(圖二)所示)
- (2).Put one Foam Board in the upper and lower of the paper box,,2PCS in all,as shown in drawing One.  
 (每箱上下各放一塊保麗龍,共2PCS,如(圖一)所示)
- (3).Put 1 PCS waterproof in the paper box,as shown in drawing Two.  
 (紙箱內側放入防水袋 1 PCS.如(圖二)所示)
- (4).Piled the XX packing plates packed up in the waterproof.  
 (將放滿產品的XX個PVC盤疊起,裝入防水袋內)
- (5).Seal the waterproof bag,then put the Foam Board 1PCS on the bag.  
 (Put 1 PCS Foam Board at the right and left side in the paper box if it is necessary.)  
 (封上防水袋,然後放上第二塊保麗龍薄板)  
 (必要時,在紙箱的左右兩側各放一塊保麗龍)
- (6).Seal the surface of the outer box.  
 (將外箱上層封口.)  
 The form on the right and flank side of the box must be filled correctly and clearly,take actual testing weight as the standard of each box gross weight.  
 外箱之正麥和側麥所要填寫之項目要填寫正確,清晰,每箱之毛重應以實測重量為準.

# 歐品電子(昆山)有限公司

OUPIIN ELECTRONIC(KUNSHAN) CO.,LTD.

## PACKAGING SPECIFICATION (包裝作業規範)

CONFIDENTIAL     TOP SECRET

SPEC.NO.(規範編號)		Q9001SPP-311T1									
PACKING MATERIAL (包裝材料)		PRODUCT P/N		CT NO.	PACKING N.W	PACKING QUANTITY (包裝數量)			WEIGHT (重量) kg		
MATERIAL NAME (材料名稱)	PART NO. (料號)	Q'TY	(產品料號)	(紙箱規格)	(包材重量)	PCS/TRAY	TRAY/BOX	PCS/BOX	N.W./PCS	N.W./BOX	G.W./BOX
PAPER BOXES (紙箱)	CT-1.6	1	9001-51151xA	CT-1.6	3.54	28	18	504	0.02730	13.76	17.30
Packing Box (包裝盒)	PET-077	----									
Packing Box Cover (包裝盒蓋子)	PVC-073	1									
WATERPROOF BAG (防水袋)	PE100*110	2									
Foam (保麗龍)	-----	3									
DRYING AGENT (干燥劑)	-----										

1.NOTE:

(注意)

When the finished products have been made,take the actual weight as the standard of gross weight in each box.(成品出貨時,每箱之毛重應以實測重量為準)

When the finished products have been made,stick the proper designation list on the box according to product demand .(成品出貨時,依據出貨要求貼上相對應的標籤單)

CT1.6 Produce goods taiwan, CT1.9 Produce goods shanghai.(CT-1.6出貨台灣OP, CT-1.9出貨上海SH)

It doesn't influence the manner of packing with the gold-plated way to print word way,Can amalgamate. (印字方式跟鍍金方式不影響包裝方式，可以共用)