

# 歐品電子(昆山)有限公司

OUPIIN ELECTRONIC(KUNSHAN) CO.,LTD.

PACKAGING SPECIFICATION (包裝作業規範)

SPEC.NO.(規範編號)	8952SPP-A2X1A	適用產品: 8952-A2X1CxxPExA & 8952-A2X1CxxPxxA	PAGE	1/1	REV.	I665-A4
----------------	---------------	---	------	-----	------	---------

PACKING OPERATION DIAGRAM & INSTRUCTION (包裝作業圖示及說明)	REMARK (備註)
---	-------------

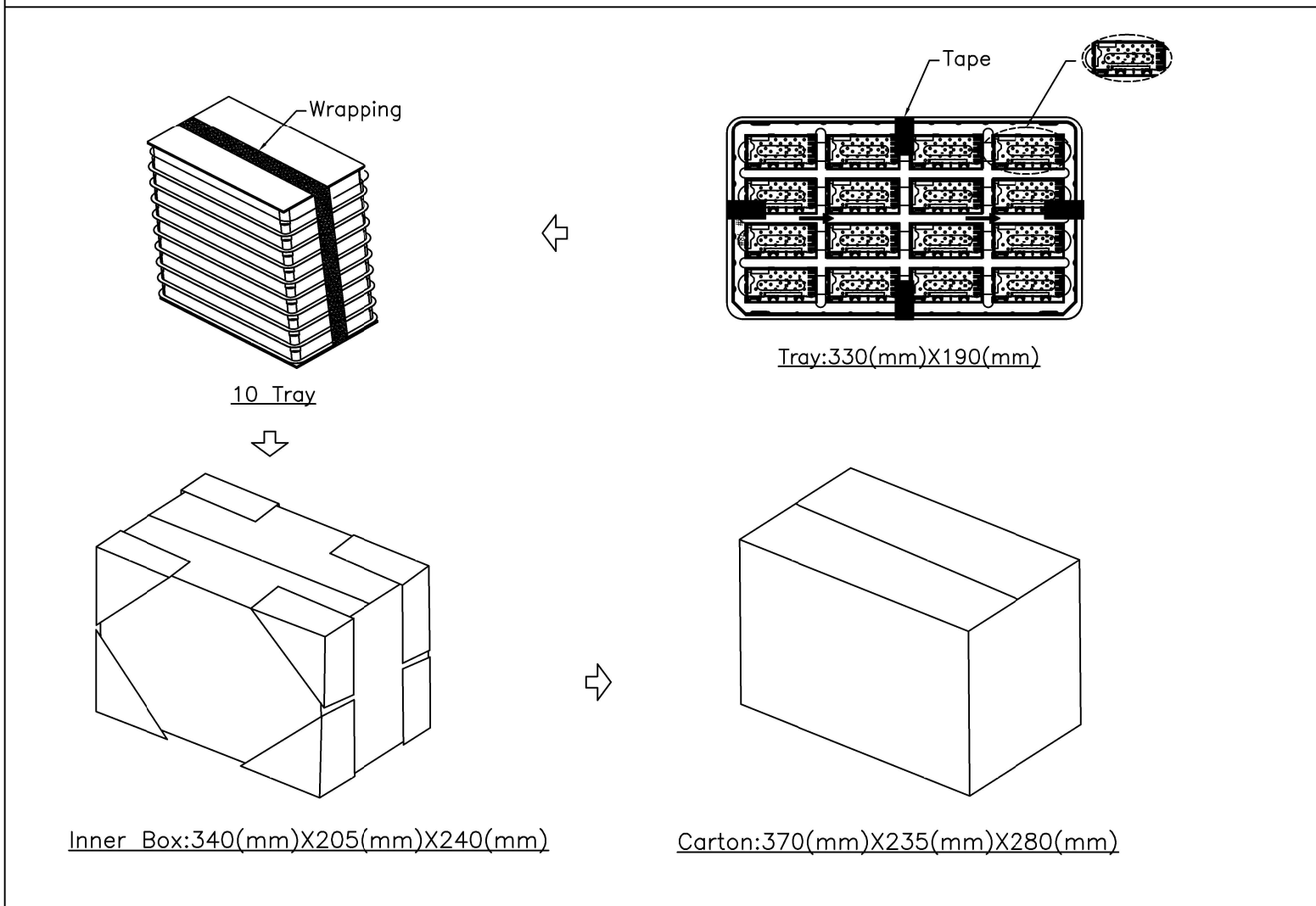

**Package:**  
 16 Pcs/ Tray  
 10 Tray/ Inner Box  
 1 Inner Box/ Carton  
 160 Pcs/ Carton

**Carton:**  
 8952-A2X1C15PE0A:  
 N.W.: 3.8 Kg  
 G.W.: 4.8 Kg  
 8952-A2X1C15PP0A:  
 N.W.: 3.6 Kg  
 G.W.: 4.7 Kg  
 8952-A2X1C15PP1A:  
 N.W.: 3.8 Kg  
 G.W.: 4.9 Kg  
 8952-A2X1C15PP2A:  
 N.W.: 3.8 Kg  
 G.W.: 4.9 Kg  
 8952-A2X1C15PP3A:  
 N.W.: 3.9 Kg  
 G.W.: 5.0 Kg  
 8952-A2X1C15PS0A:  
 N.W.: 3.6 Kg  
 G.W.: 4.7 Kg  
 8952-A2X1C15PS1A:  
 N.W.: 3.8 Kg  
 G.W.: 4.9 Kg  
 8952-A2X1C15PS2A:  
 N.W.: 3.8 Kg  
 G.W.: 4.9 Kg  
 8952-A2X1C15PS3A:  
 N.W.: 4.0 Kg  
 G.W.: 5.0 Kg

Drawn By: Sherry 06/18'19