

Part List

1	Raw Cable	4X10G 8Pair, PVC, Black
2	PCB Assembly	QSFP+ PCB, 38P, Gold Plated 30u".
3	Shell	Zn Alloy, Nickel Plated over Cu.
4	Latch	Stainless Steel
5	Pull Tab	PA66 S1300, Deep Blue
6	Spring	Handed Potation, SWPB
7	Rivet	Aluminium Alloy
8	Inner Mold	Hot-Melt Glue
9	SR	PVC 45P
10	Label	Back Shell Label, 29.5*9.6mm
*RoHS Compliant		

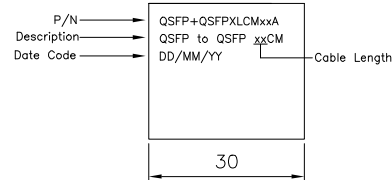
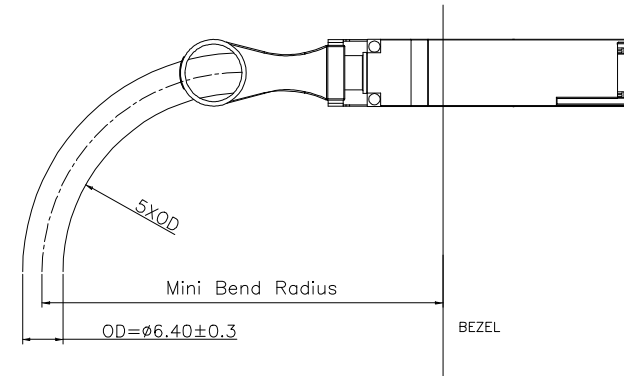
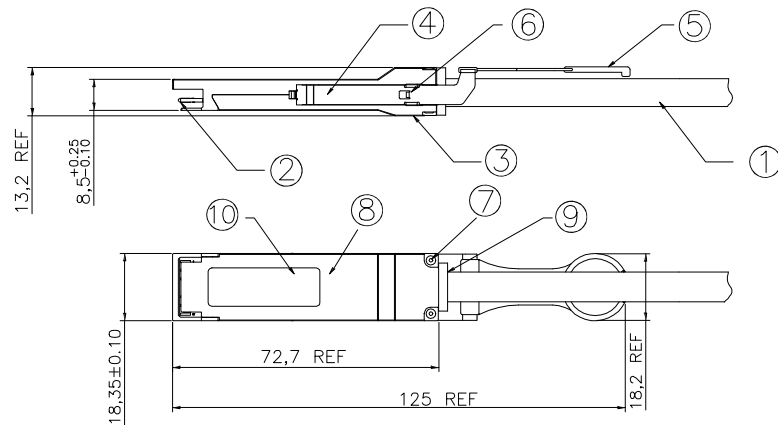
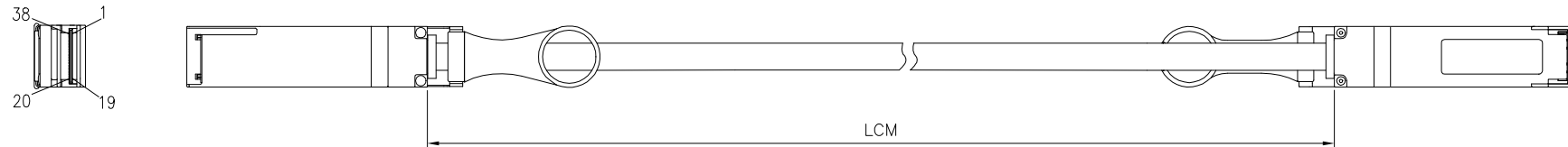

QSFP + QSFP X L CM 30A
 QSFP ————
 QSFP ————
 30: 30 AWG
 L: Cable Length

Length(L)	Wire Gauge	Mini Bend Radius
50±2cm	30AWG	65mm
100±2cm	30AWG	
150±2cm	30AWG	
200±2cm	30AWG	
250±4cm	30AWG	
300±4cm	30AWG	

NOTE:

- 1.Cable Assembly Impedance: 100±15ohm.
- 2.100% Conductor test, Conduction Resistance Max 3 ohm.
- 3.High-FreQuency test According to IEEE802.3ba Standard.



LABEL DETAIL

Tolerances	Dwg. No.	S2320220609-02	Part No.		OUPIIN ENTERPRISE CO., LTD.
x. = ±0.50 .x = ±0.20 .xx = ±0.10 .xxx = ±0.05	Projection			QSFP+QSFPXLCMxxA	
	Unit	mm	Scale	1:N	
	Drawn By	Martin	Date	06/09'22	

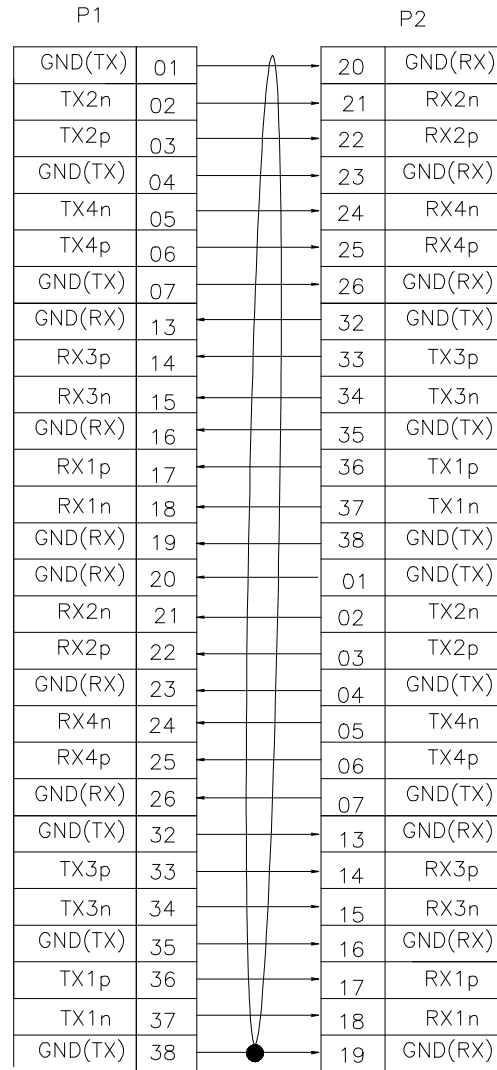
WIRING TABLE



LOW SPEED SIGNALS	
P1 & P2	
08	ModSell
09	ResetI
10	VccRx
11	SCL
12	SDA
27	ModPrsL
28	IntL
29	VccTx
30	Vcc1
31	LPMoDe

Tolerances x. = ±0.50 .x = ±0.20 .xx = ±0.10 .xxx = ±0.05	Dwg. No.	S2320220609-02		Part No.	QSFP+QSFPXLCMxxA		 OUPIIN ENTERPRISE CO., LTD.
	Projection			Title:	QSFP to QSFP Cable Assembly		
	Unit mm	Scale	1:N		Date	Rate 40G	
	Drawn By	Martin 06/09'22		①517			SHEET 2/2 Ver.No. X1