

# 歐品電子(昆山)有限公司

OUIIN ELECTRONIC(KUNSHAN) CO.,LTD.

PACKAGING SPECIFICATION (包裝作業規範)

CONFIDENTIAL  TOP SECRET

SPEC.NO.(規範編號) Q9394SPP-1882		APPLICABLE PRODUCT (適用產品) 9394-4A3P111ACB30DA		PAGE 1/4	REV. A
APPLICABLE CUSTOMER (適用客戶) ALL				PACKAGING CATEGORY (包裝方式) TRAY PLATE PACKING	

## REVISION HISTORY (修訂履歷)

ECN REV. NO	PAGE (頁次)								
	1	2	3	4					
A	NEW (新版發行)								

DIVISION (事業單位) Product Development (產品開發課)	APPROVED (核准)	CHECKED (審核)	PE: DE:	PREPARED (制表)	CXP 05/22'18
---	---------------	--------------	---------	---------------	--------------

# 歐品電子(昆山)有限公司

OUIIN ELECTRONIC(KUNSHAN) CO.,LTD.

PACKAGING SPECIFICATION (包裝作業規範)

<input checked="" type="checkbox"/> CONFIDENTIAL	<input type="checkbox"/> TOP SECRET		
PAGE	2/4	REV.	A

SPEC.NO.(規範編號) Q9394SPP-1882

PACKING OPERATION DIAGRAM & INSTRUCTION (包裝作業圖示及說明)

REMARK (備注)

Laying Product Diagram:

(產品擺放圖示)

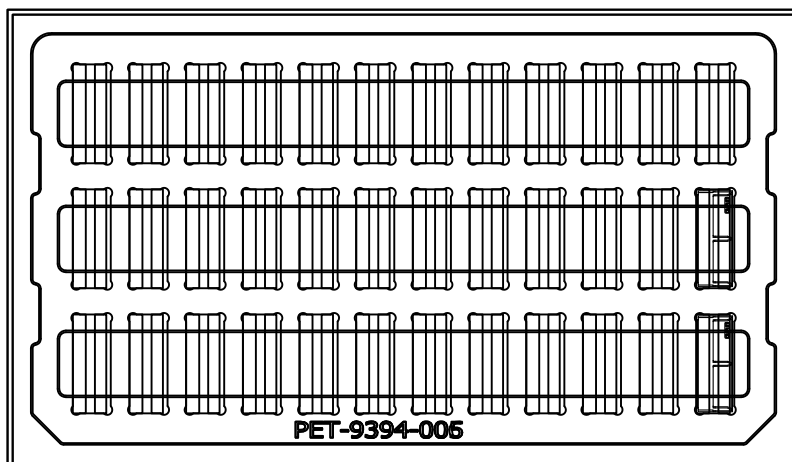

一.PET Plate Packing Mode:  
(PET盤包裝方式)

(1).CT-0.9 Box: PET-9394-004 xx PCS.

(CT-0.9規格的紙箱放PET-9394-004 xx PCS)

(2).Put product in each trough fully as shown in diagram.  
(產品在盤子中擺放方式如圖所示)

(3).After filling each trough with product fully,cover it  
with transparent upper cover PET-9394-005 1PCS。  
(每盤放滿產品後,加蓋透明上蓋 PET-9394-005 1PCS)

(4).Stack the XX PET plates filled with product, put them in  
the paper box in which has been put waterproof bag.  
(將放滿產品的XX個PET盤疊起,裝入防水袋放入紙箱內)

# 歐品電子(昆山)有限公司

OUPHIN ELECTRONIC(KUNSHAN) CO.,LTD.

PACKAGING SPECIFICATION (包裝作業規範)

■ CONFIDENTIAL □ TOP SECRET			
PAGE	3/4	REV.	A

SPEC.NO.(規範編號) Q9394SPP-1882

## PACKING OPERATION DIAGRAM & INSTRUCTION (包裝作業圖示及說明)

## REMARK (備注)

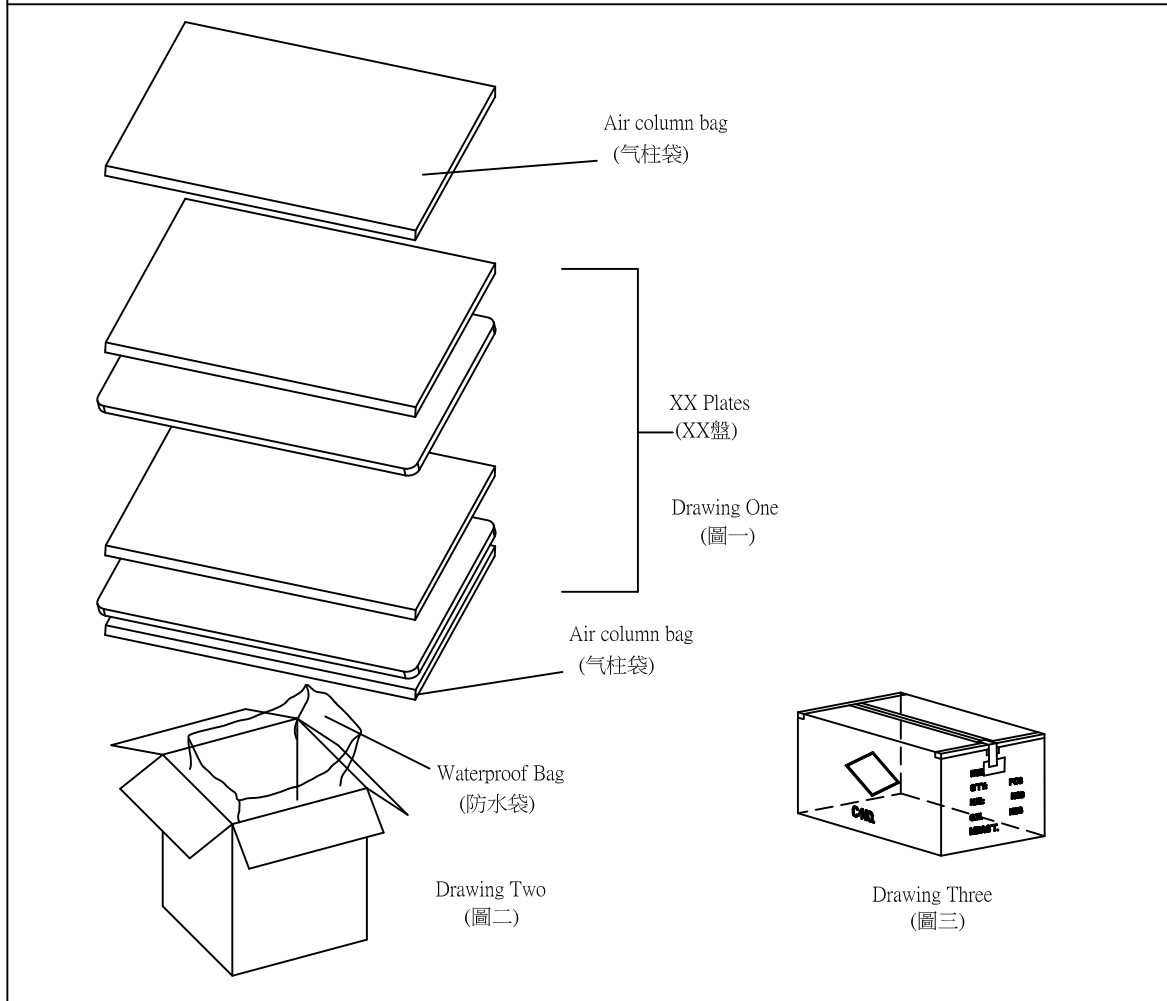

### 一. Outer Box Packing Mode: (外箱包裝方式)

- (1). Paper box 0.5 standard 1 PCS, as shown in drawing Two.  
(紙箱 0.5 規格 1 PCS, 如(圖二)所示)
  - (2). Put one Air column bag in the upper and lower of the paper box, 2PCS in all, as shown in drawing One.  
(每箱上下各放一塊气柱袋, 共2PCS, 如(圖一)所示)
  - (3). Put 1 PCS waterproof in the paper box, as shown in drawing Two.  
(紙箱內側放入防水袋 1 PCS, 如(圖二)所示)
  - (4). Piled the XX PET plates packed up in the waterproof.  
(將放滿產品的XX個PET盤疊起, 裝入防水袋內)
  - (5). Seal the waterproof bag, then put the Air column bag 1PCS on the bag, if box can not be filled, filled with ploy.  
(Put 1 PCS Air column bag at the right and left side in the paper box if it is necessary.)  
封上防水袋後, 放上第二塊气柱袋, 未填滿處用气柱袋填滿.  
(必要時, 在紙箱的左右兩側各放一塊气柱袋)
  - (6). Seal the surface of the outer box, as shown in drawing Three.  
(將外箱上層封口, 如(圖三)所示)
- The form on the right and flank side of the box must be filled correctly and clearly, take actual testing weight as the standard of each box gross weight.
- 外箱之正麥和側麥所要填寫之項目要填寫正確, 清晰, 每箱之毛重應以實測重量為準.

# 歐品電子(昆山)有限公司

OUPIIN ELECTRONIC(KUNSHAN) CO.,LTD.

## PACKAGING SPECIFICATION (包裝作業規範)

<input checked="" type="checkbox"/> CONFIDENTIAL		<input type="checkbox"/> TOP SECRET	
PAGE:	4/4	REV.	A

SPEC.NO.(規範編號) Q9394SPP-1882

PACKING MATERIAL (包裝材料)			PRODUCT P/N	CT NO.	PACKING N.W.	PACKING QUANTITY (包裝數量)			WEIGHT (重量) kg		
MATERIAL NAME (材料名稱)	PART NO. (料號)	Q'TY	(產品料號)	(紙箱規格)	(包材重量)	PCS/TRAY	TRAY/BOX	PCS/BOX	N.W./PCS	N.W./BOX	G.W./BOX
PAPER BOXES (紙箱)	CT-0.5	1	93944A3P111ACB30DA	CT-0.5	4.18475	36	6	216	0.01229	2.65464	6.83939
Packing Box (包裝盒)	PET-9394-005	----									
Packing Box Cover (包裝盒蓋子)	PET-9394-006	----									
WATERPROOF BAG (防水袋)	PE 100*90	1									
Air column bag (氣柱袋)	-----	2									
DRYING AGENT (干燥劑)	-----	3									

1.NOTE:  
 (注意)  
 When the finished products have been made,take the actual weight as the standard of gross weight in each box.  
 (成品出貨時,每箱之毛重應以實測重量為準)  
 When the finished products have been made,stick the proper designation list on the box according to product de  
 CT-1.6 Produce goods taiwan , CT-1.9 Produce goods shanghai. (CT-1.6出貨台灣OP , CT-1.9出貨上海SH)  
 It doesn't influence the manner of packing with the gold-plated way to print word way.Can amalgamate.(印字方式跟鍍金方式不影響包裝方式,可以共用)