



# PRODUCT SPECIFICATION

## 產品規格書

產品名稱 Description	產品料號 Part No.	圖號 Drawing No.
High Speed Board to Board Pitch 0.5mm Connector	2336-xxMCxDxxx-x(-Axxx)	2336-D0000-xxx
	2336-xxFCxDxxx-x(-Axxx)	2336-D0000-xxx

PRODUCT NAME 產品名稱	DOCUMENT No.: 文件編號	Rev. 版本	OUPIIN
High Speed Board to Board Pitch 0.5mm Connector (RoHS)	Q2336-PSS-K001	A (I800)	歐品電子
	Approved 核准	Checked 審核	Prepared 製作
	Q.A. Section Chief	Ruru Chen	2024.04.23



# PRODUCT SPECIFICATION OF OUPIIN

## 1. SCOPE 適用範圍

This product specification defines the product performance and the test methods to ascertain the performance of the High Speed Board to Board Pitch 0.5mm Connector, which is designed and manufactured by Oupiin Electronic Co., Ltd. This product specification is applicable but not only for those part numbers which be shown in the cover page.

本產品規格書規定了由歐品電子有限公司設計生產的 High Speed Board to Board Pitch 0.5mm 型連接器產品的特性及測試方法。本產品規格書適用於但不局限於封面所顯示的產品料號。

## 2. REFERENCE DOCUMENTS 參考文件

MIL-STD-1344	Test method for electrical connector	電子連接器測試方法
MIL-STD-202	Test method for electrical components	電子零件測試方法
EIA364	Test method for electrical components	電子零件測試方法
JIS C 0051	Test method for electrical components	電子零件測試方法
MIL-G-45204C	Specification for gold plating	鍍金規格
IEC-512-3	IEC standard for current carrying capacity tests	IEC電流測試標準
QQ-N-290A	Specification for nickel plating	鍍鎳規格
MIL-P-81728A	Specification for tin/lead plating	鍍錫鉛規格
MIL-T-10727B	Specification for tin plating	鍍錫規格
UL1977	UL standard for safety of attachment plug and receptacle	UL安規要求標準

## 3. FEATURE & DIMENSIONS 特徵及尺寸

### 3.1. PRODUCT DIMENSION 產品尺寸

These connectors shall have the dimensions as shown in drawing.

本產品的相關尺寸參見圖面。

### 3.2. MALE AND FEMALE PRODUCT 公母產品裝配

#### 3.2.1. Male and female assembly dimension 公母產品裝配尺寸

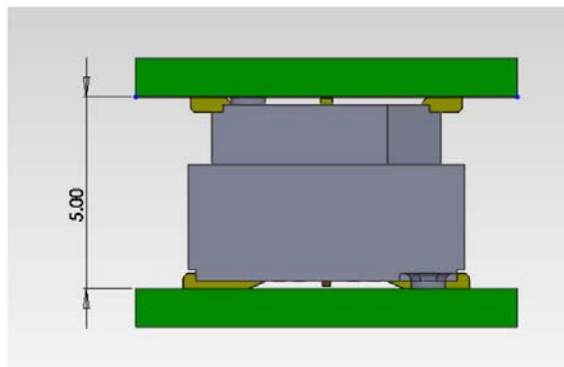

Distance between male's PCB and female's PCB is 5.00REF 公母PCB板之間的尺寸為5.00REF

## 3.2.2. Perpendicular to engaging direction 垂直插入方向

The design of the centering and guiding in the Mpc of the free and fixed board connector modules shall accept a misalignment of 0.40mm in transverse and 0.50mm in longitudinal axes of the connector

固定板連接器模件的Mpc裡，連接器設計中心線橫向可接受0.40mm和縱向可接受0.50mm的偏差。

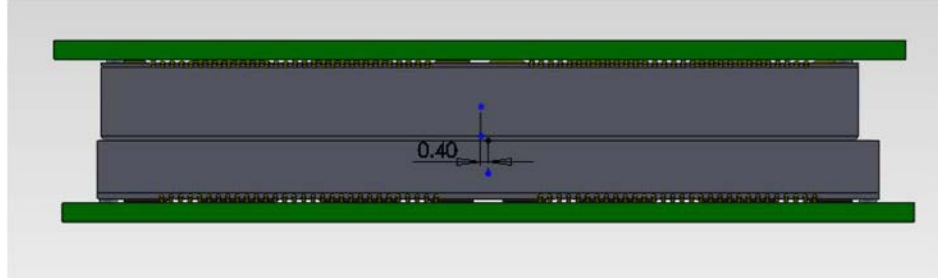

allowed misalignment in transverse axes 在橫向方向允許對插容差

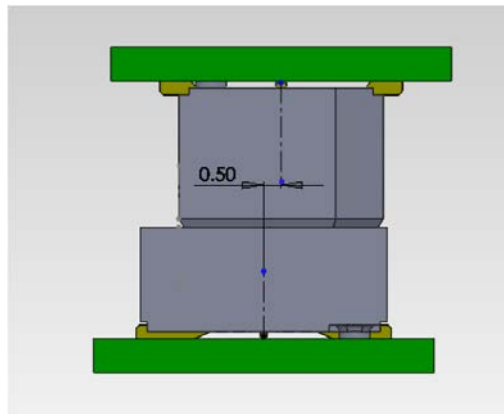

allowed misalignment in longitudinal axes 在縱向方向允許對插容差

## 3.2.3. Inclination 傾向

The center and guiding in the Mpc of the free and the fixed board connector modules shall allow an initial angular misalignment of 2° from both the transverse and longitudinal axes

固定板連接器模件的在Mpc裡，連接器可接受橫向和縱向2°的最大傾斜對插角度。

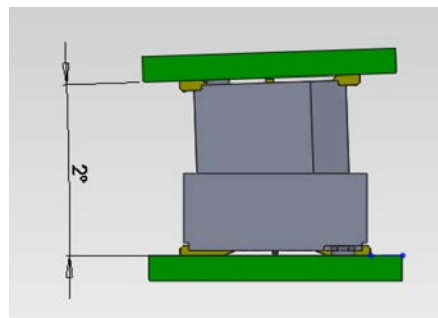
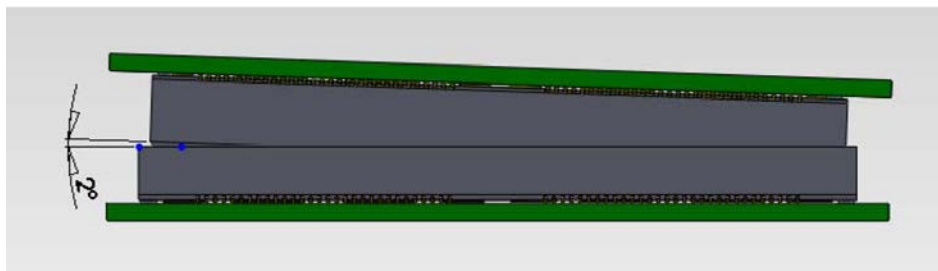



## PRODUCT SPECIFICATION OF OUPIIN

### 3.3. PCB/PANEL LAYOUT 印刷電路板佈局

The recommended PCB layout is shown in drawing.

本產品適用的 PCB layout 參見圖面。

### 3.4. BILL OF MATERIAL 材料清單

Harmful material controlling follows the requirements of RoHS. The bill of material is described in drawing.

有害物質控制符合RoHS指令要求。本產品使用的材料參見圖面。

### 3.5. MECHANICAL & ELECTRICAL CHARACTERISTIC 機械及電氣特性

The connector shall have the mechanical and electrical performance as described in drawing.

本產品的機械及電氣特性參見圖面。

### 3.6. PACKAGING 包裝

Products shall be packaged according to requirements specified in purchase order for safe delivery, connector container and the packaging method are shown in package specification.

產品可依客戶指定要求包裝，包裝材料與包裝方式參見產品包裝規範。

### 3.7. RATING CURRENT AND RATING VOLTAGE 額定電流與額定電壓

Rating current : Signal Pin 3A per contact with 3 adjacent contacts (UL).

Rating voltage : 125V AC RMS.

額定電流：信號 Pin 3A 每 Pin 串聯 3 Pin (UL)

額定電壓：125V AC RMS

### 3.8. STORAGE AND OPERATING TEMPERATURE 儲存與使用溫度

Temperature range :  $-55^{\circ}\text{C} \sim +125^{\circ}\text{C}$ , including terminal temperature rise for rating current.

Storage Temperature :  $0^{\circ}\text{C} \sim +40^{\circ}\text{C}$ , Humidity : 80%RH under. Time limit is 12 months the products are stored.

溫度範圍： $-55^{\circ}\text{C} \sim +125^{\circ}\text{C}$ ，包含接觸端子的額定電流溫升。

儲存溫度： $0^{\circ}\text{C} \sim +40^{\circ}\text{C}$ ，濕度：80%RH 以下，產品限存時間為 12 個月。

## 4. Environmental 環境要求

### 4.1. SOLDERABILITY 可焊性

Connectors meet solder-ability to EIA-364-52, and shall be free of contaminants.

產品可焊性符合EIA-364-52標準規定的相關要求，表面不得有污染物。



## 4.2. RESISTANCE TO SOLDER HEAT 耐焊接熱

### 4.2.1. INFRARED REFLOW 紅外線回流焊接

Each cycle consists of three consecutive phases, as shown in **Table III**.

每個焊接週期包括三個連續的階段，見附表三。

**Note:** 說明

Device temperature measurements are referenced from the top-center of the package outer surface.

設備溫度量測時以從頂部中間位置測量為準。

## 5. PERFORMANCE AND TEST DESCRIPTION 性能及測試

### 5.1. REQUIREMENT 要求

Product is designed to meet electrical, mechanical, and environmental performance requirements specified in Table I.

本產品設計符合附表一所述的機械，電氣及環境要求。

### 5.2. TEST CONDITION 測試條件

Unless otherwise specified, all tests shall be performed at ambient environmental conditions.

除非特別註明，所有測試在室溫條件下完成。

### 5.3. SAMPLE SELECTION 樣品選擇

Test samples shall be selected at random from current production. No test samples shall be reused.

Samples are pre-conditioned with 10 cycles of durability. Each group shall be containing 5 test samples at least.

測試樣品從現生產的產品中隨機抽取，所有測試過的樣品不得重複使用。樣品已預先插拔10次，每組測試至少有5個樣品。

### 5.4. TEST SEQUENCE 測試順序

Product qualification test sequence as shown in Table II.

產品品質測試順序見附表二。



## PRODUCT SPECIFICATION OF OUPIIN

### Table I : Test Requirements and Methods

#### 附表一：測試要求與方法

Items 項目	Requirements 要求	Test Methods 測試方法
1. Confirmation of Product 產品確認	Product shall be conforming to the requirements of applicable product drawing. 產品必須符合相關產品圖面的要求。	Visually, dimensions and functionally inspected per applicable product drawing. 依相關產品圖面，檢查產品的外觀、尺寸及功能。
2. Contact Resistance 接觸阻抗	Initial, Signal Pin 45 mΩ Max. 初始狀態，信號端子最大 45 mΩ。	Subject mated contacts assembled in housing to closed circuit of 100 mA max. 20 mV max. Per EIA-364-06. 所述固定在外殼裡的端子連結到一個封閉回路中測試，電流 100 mA max，電壓 20 mV max。 適用：EIA-364-06
3. Insulation Resistance 絕緣阻抗	5000 MΩ Min. 最小 5000 MΩ	Measure by applying test potential between the adjacent contacts, and between the contacts and ground in the mated connector. Per EIA-364-21. 測試產品相鄰端子間以及端子與接地間的電阻。 適用：EIA-364-21
4. Dielectric Withstanding Voltage 耐電壓	Connector must withstand test potential of 525 VAC RMS for 1 minute, current leakage must be 0.2mA Max. 產品必須承受測試電壓 525 VAC RMS，時間 1 分鐘，漏電流不大於 0.2 mA。	Measure by applying test potential between the adjacent contacts, and between the contacts and ground in the mated connector. Per EIA-364-20. 對產品相鄰端子間以及端子與接地間加載電壓，並測試其漏電流。 適用：EIA-364-20
5. Durability (Repeated Mating/Un-mating) 耐久性	Contact Resistance $\Delta$ 15 mΩ Max. after testing. 測試後，接觸阻抗變化最大 15 mΩ。	Repeat mate and unmated for connector 250 cycles, at a speed of 25.4 mm per minute. Per EIA-364-09 重複進行配合產品 250 次插拔，速度 25.4mm/分鐘。 適用：EIA-364-09



## PRODUCT SPECIFICATION OF OUPIIN

<p>6. Connector Mating /Un-mating Force 插入力/拔出力</p>	<p>Signal pin : Mating force : 0.42N/Pin Max. Un-mating force : 0.08N/Pin Min 信號端子： 插入力最大 0.42N/Pin 拔出力最小 0.08N/Pin</p>	<p>At a speed of 25±3 mm/minute, apply axial insert the mating part into fully or pull out from the subject product. Per EIA-364-13 以 25±3 mm/分鐘的速度，軸向完全插入對配外掛程式到被測產品中或從被測產品中拔出。 適用：EIA-364-13</p>
<p>7. Contact Retention Force 端子保持力</p>	<p>1.2 N/Pin. Min. 最小 1.2 N/Pin</p>	<p>Apply axial pull out force at a speed of 25±3 mm/minute on the contact assembled in the housing. Per EIA-364-29 以 25±3mm/分鐘的速度施加軸向拉力從塑膠本體上拔出端子。 適用：EIA-364-29</p>
<p>8. Vibration Sinusoidal Low Frequency 低頻正弦振動</p>	<p>No electrical discontinuity greater than 0.05 μs shall occur, Contact Resistance Δ15 mΩ Max. 不允許出現超過 0.05 μs 的瞬間斷開，接觸阻抗變化最大 15 mΩ。</p>	<p>Subject mated connector to 50-2000 Hz traversed in 1 minute at 1.5 mm amplitude, 2 hours each of 3 mutually perpendicular plane, 10 mA potential applied. Per EIA-364-28. 對測試產品，在頻率變化每分鐘從 50-2000 Hz, 振幅 1.5 mm 條件下，在互相垂直的三個面上，每個面 2 小時下測量，電流 10 mA。 適用：EIA-364-28</p>
<p>9. Mechanical Shock 機械沖擊</p>	<p>No electrical discontinuity greater than 0.05 μs shall occur, Contact Resistance Δ 15 mΩ Max. 不允許出現超過 0.05 μs 的瞬間斷開，接觸阻抗變化最大 15 mΩ。</p>	<p>Subject mated connector and shock at 100g with 1/2 sine wave (6 millisecond) shocks in the 3 axes(18 shocks total). Per EIA-364-27 加載 100g 半正弦波，持續 6 毫秒，三個方向共 18 次。 適用：EIA-364-27</p>
<p>10. Thermal Shock 溫度沖擊</p>	<p>After testing, no damage, Contact Resistance Δ15 mΩ Max. Dielectric Strength should be OK, Insulation Resistance should be 5000 MΩ Min. 測試後，產品無損壞，接觸阻抗變化最大 15mΩ；耐電壓測試 OK，絕緣阻抗最小 5000 MΩ。</p>	<p>Temperature range from -55°C to +85°C. Start from -55°C, after 30 minutes, change to +85°C; change time is no more than 30 seconds, total 100 cycles. Per EIA-364-32. 溫度變化範圍：-55°C ~ +85°C。從 -55°C 開始，30 分鐘後換到 +85°C，轉換時間不超過 30 秒，共 100 個循環。 適用：EIA-364-32</p>



## PRODUCT SPECIFICATION OF OUPIIN

<p>11. Humidity (Steady State) 恆溫恆濕</p>	<p>After testing, no damage, Contact Resistance <math>\Delta 15 \text{ m}\Omega</math> Max. Dielectric Strength should be OK, Insulation Resistance should be 5000 M<math>\Omega</math> Min. 測試後，產品無損壞，接觸阻抗變化最大 15m<math>\Omega</math>；耐電壓測試 OK，絕緣阻抗最小 5000 M<math>\Omega</math>。</p>	<p>Temperature : 25<math>^{\circ}\text{C}</math> to 65<math>^{\circ}\text{C}</math> Relative Humidity : 90-95%. Duration : 240 Hours. Per EIA-364-31. 溫度：25<math>^{\circ}\text{C}</math>到 65<math>^{\circ}\text{C}</math> 相對濕度：90-95% 持續時間：240 小時 適用：EIA-364-31</p>
<p>12. Solder-ability 可焊性</p>	<p>Appearance of the specimen shall be inspected after the test with the assistance of a magnifier capable of giving a magnification of 10 X for any damage such as pinholes, void or rough surface. 產品在測試完成後，在放大倍數為 10 倍的顯微鏡下，檢查外觀損壞如：小孔，空焊，外觀粗糙度。</p>	<p>Soldering time : 5 seconds. Temperature : 245<math>\pm 5^{\circ}\text{C}</math> Per EIA-364-52. 焊接時間：5 秒 溫度：245<math>\pm 5^{\circ}\text{C}</math> 適用：EIA-364-52</p>
<p>13. Test temperature rise for rating current 溫升測試</p>	<p>The test temperature above ambient shall not exceed RTI(130<math>^{\circ}\text{C}</math>) for UL. Ambient conditions - Still air 25<math>^{\circ}\text{C}</math> 測試溫度不能超過 UL 標準的 RTI(130<math>^{\circ}\text{C}</math>)值。 周圍環境溫度 25<math>^{\circ}\text{C}</math>。</p>	<p>Subject mated contacts assembled in housing to closed circuit of 3A per contact with 3 adjacent signal contacts, 250V max, Test Specification for 8 hours continuously. Per EIA-364-70. 所述固定在外殼包的端子連結到一個封閉回路中測試，信號端子 3A 串聯 3 PIN，250V max，連續 8 小時。 適用：EIA-364-70</p>
<p>14. Salt Spray 鹽霧</p>	<p>After testing, no damage, Contact Resistance <math>\Delta 15 \text{ m}\Omega</math> Max. Dielectric Strength should be OK, Insulation Resistance should be 5000 M<math>\Omega</math> Min. 測試後，產品無損壞，接觸阻抗變化最大 15m<math>\Omega</math>；耐電壓測試 OK，絕緣阻抗最小 5000 M<math>\Omega</math>。</p>	<p>5<math>\pm 1\%</math> salt concentration, 48 hours, 35<math>\pm 2^{\circ}\text{C}</math>. Per EIA-364-52. 鹽水濃度 5<math>\pm 1\%</math>，時間 48 小時，溫度 35<math>\pm 2^{\circ}\text{C}</math>。 適用：EIA-364-52</p>
<p>15. High Temperature Life 高溫老化</p>	<p>After testing, no damage, Contact Resistance <math>\Delta 15 \text{ m}\Omega</math> Max. Dielectric Strength should be OK, Insulation Resistance should be 5000 M<math>\Omega</math> Min. 測試後，產品無損壞，接觸阻抗變化最大 15m<math>\Omega</math>；耐電壓測試 OK，絕緣阻抗最小 5000 M<math>\Omega</math>。</p>	<p>Subject product to 105<math>\pm 3^{\circ}\text{C}</math> for 250 hours continuously. Per EIA-364-17. 產品置於 105<math>\pm 3^{\circ}\text{C}</math>，連續 250 小時。 適用：EIA-364-17</p>





PRODUCT SPECIFICATION OF OUPIIN

**Table II : Product Qualification Test Sequence**

附表二：產品測試順序

Test Description 測試描述	Test Group 測試分組									
	A	B	C	D	E	F	G	H	I	J
1. Conformation of Product 產品確認	1,7	1,4	1,9	1,9	1,9	1,9	1,3	1,9	1,9	1,9
2. Contact Resistance 接觸阻抗	2,6		2,6	2,6	2,6	2,6		2,6	2,6	2,6
3. Insulation Resistance 絕緣阻抗	3		3,7	3,7	3,7	3,7		3,7	3,7	3,7
4. Dielectric Withstanding Voltage 耐電壓	4		4,8	4,8	4,8	4,8		4,8	4,8	4,8
5. Durability 耐久性	5									
6. Connector Mating/Un-mating Force 插入/拔出力		2								
7. Contact Retention Force 端子保持力		3								
8. Vibration Sinusoidal Low Frequency 低頻正弦振動			5							
9. Mechanical Shock 機械沖擊				5						
10. Thermal Shock 溫度沖擊					5					
11. Humidity (Steady State) 恆溫恆濕						5				
12. Solder-ability 可焊性							2			
13. Test temperature rise for rating current 溫升測試								5		
14. Salt Spray 鹽霧									5	
15. High Temperature Life 高溫老化										5

**Table III : Reflow Soldering Profile**

附表三：回流焊接曲線圖

Lead-free reflow profile requirements:

無鉛回流焊接曲線

Parameter 參數	Reference 參考	Specification 規格
升溫區 Ramp-up	25°C ~ 150°C	3°C /S Max
預熱區(Pre-heating) Temperature Min(Tsmin) Temperature Max(Tsmax) Time(Tsmin to tsmax)	150°C ~ 200°C	60~180sec
Time maintained above(保持時間) Temperature(TL)	217°C	60~150sec
Time within 5°C of actual peak Temperature(tp)	260±5°C	20~40sec
冷卻區 Cooling	Ramp-Down Rate	6°C /S(Max)
Time 25°C to Peak Temperature	25°C ~ Peak Temp.	8 minutes maximum

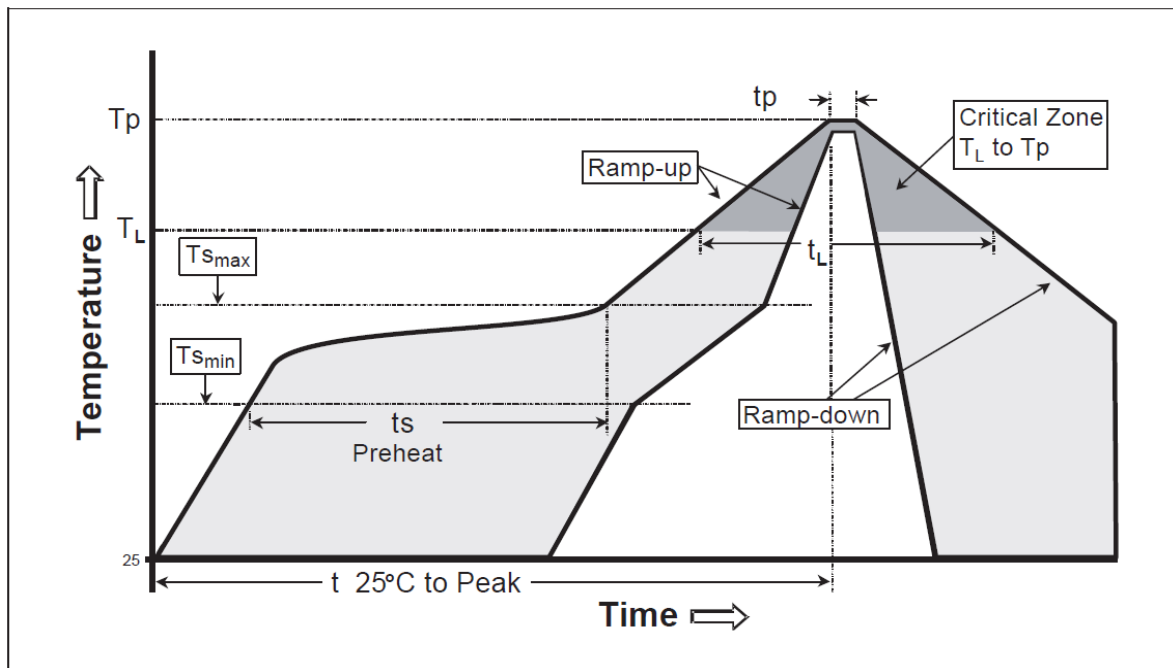

This profile is the minimum requirement for evaluating soldering heat resistance of components .Heat transfer method used for reflow soldering is hot air convection .The actual air temperatures used to achieve the specified profile largely dependent on the reflow equipment.

這個曲線圖是評估元件器件焊接抗熱的基本要求。應用在對焊接中的熱傳遞方式是熱氣對流。達到特定曲線圖地實際溫度主要依賴與回流焊接設備。