

REV.	SPECIFICATION	ECN NO.	APPD.

**Material:**

Housing: PA6T, UL94V-0, Black.  
 Contacts: Brass, Gold Plated or 80~120u" Tin Plated over Nickel 50u".

**Electrical Characteristics:**

Current Rating: 3 AMP.  
 Dielectric Withstanding Voltage: AC 500V.  
 Insulator Resistance: 1000MΩ min.  
 Contact Resistance: 20mΩ max.  
 Operating Temperature: -40°C~+105°C.  
**\*RoHS Compliant**

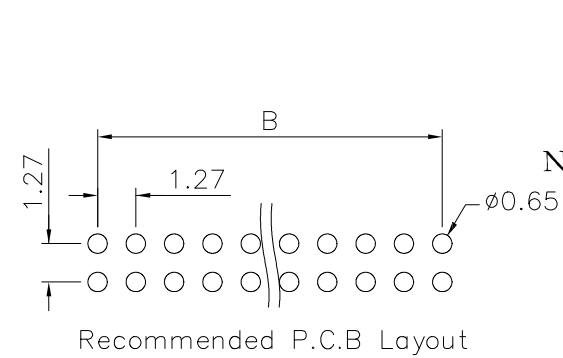
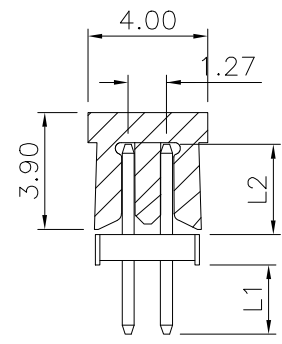
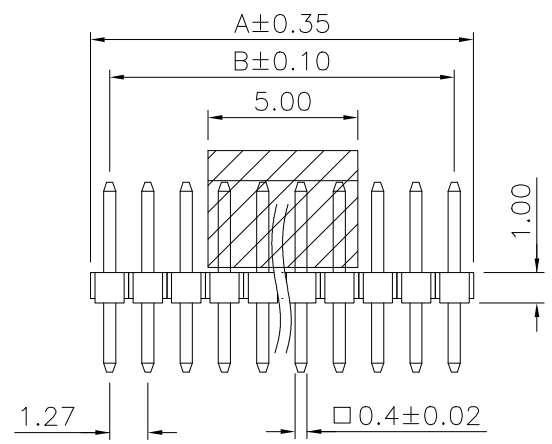
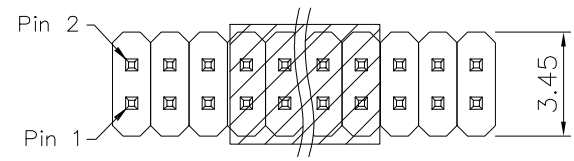

Series: 2215- 2 X xx G 00 S -L1 -L2 T -P  
 Double Row  
 No. of Pin Per Row  
 G:Gold Plated  
 T: Tin Plated  
 00:Gold Flash  
 10: 10u"  
 15: 15u"  
 30: 30u"  
 Blank: For Tin Plated

P:Plastic Pad  
 Blank: W/O Pad  
 T:Tape & Reel Package  
 B: Bulk Package  
 U:Tube Package  
 L2: Mate Length  
 L1: Dip Length  
 S: Straight

ie: 2215-2XxxG00S-2.3-3T-P  
 2.3mm Dip Length (increment of 0.1mm)  
 3.0mm Mate Length (increment of 0.1mm)

Dimension					
Positions	A	B	Positions	A	B
2X02	2.34	1.27	2X27	34.09	33.02
2X03	3.61	2.54	2X28	35.36	34.29
2X04	4.88	3.81	2X29	36.63	35.56
2X05	6.15	5.08	2X30	37.90	36.83
2X06	7.42	6.35	2X31	39.17	38.10
2X07	8.69	7.62	2X32	40.44	39.37
2X08	9.96	8.89	2X33	41.71	40.64
2X09	11.23	10.16	2X34	42.98	41.91
2X10	12.50	11.43	2X35	44.25	43.18
2X11	13.77	12.70	2X36	45.52	44.45
2X12	15.04	13.97	2X37	46.79	45.72
2X13	16.31	15.24	2X38	48.06	46.99
2X14	17.58	16.51	2X39	49.33	48.26
2X15	18.85	17.78	2X40	50.60	49.53
2X16	20.12	19.05	2X41	51.87	50.80
2X17	21.39	20.32	2X42	53.14	52.07
2X18	22.66	21.59	2X43	54.41	53.34
2X19	23.93	22.86	2X44	55.68	54.61
2X20	25.20	24.13	2X45	56.95	55.88
2X21	26.47	25.40	2X46	58.22	57.15
2X22	27.74	26.67	2X47	59.49	58.42
2X23	29.01	27.94	2X48	60.76	59.69
2X24	30.28	29.21	2X49	62.03	60.96
2X25	31.55	30.48	2X50	63.30	62.23
2X26	32.82	31.75			

Tolerances .x = ±0.30 .xx = ±0.20	Dwg No.	2215D01001		Title: 2215 Series Pin Header 1.27mmX1.27mm Double Row Straight Solder Type	 OUPIIN ELECTRONIC(KUNSHAN) CO., LTD. P/N: 2215-2XxxG00S-L1-L2T-P	
	Projection					
	Unit	mm	Scale			1:1
	Drawn By	Martin 08/25'23				① 535
SHEET		1/1	Ver.No.	B3		