



PRODUCT SPECIFICATION

產品規格書

| 產品名稱 Description | 產品料號 Part No. | 圖號 Drawing No. |
|-------------------------------|----------------------|----------------|
| 1.27mm SMC Connector SMT TYPE | 2321-AxxMCxxDPxT-P | 2321-D0000-001 |
| | 2321-AxxFCxxDPxT-P | 2321-D0000-002 |
| | 2321-AxxMCxxDRPT | 2321-D0000-006 |
| | 2321-AxxFCxxDRPT | 2321-D0000-007 |
| | 2321-A1XxxMCxxDP1T-P | 2321-D0000-003 |
| | 2321-A1XxxFCxxDRPT | 2321-D0000-004 |
| | 2321-A1XxxMCxxDRPT | 2321-D0000-005 |

| PRODUCT NAME 產品名稱 | DOCUMENT No.: 文件編號 | Rev. 版本 | OUPIIN |
|-------------------------------|-----------------------|----------------------|-----------------------|
| 1.27mm SMC Connector SMT TYPE | Q2321-PSS-001 | B | 歐品電子 |
| | Approved 核准 | Checked 審核 | Prepared 制作 |
| | | | S X H 07/09'24 |



PRODUCT SPECIFICATION OF Oupiin

1. SCOPE 適用範圍

This product specification defines the product performance and the test methods to ascertain the performance of 1.27mm SMC Connector SMT TYPE , which is designed and manufactured by Oupiin Electronic Co., Ltd. This product specification is applicable but not only for those part numbers which be shown in the cover page.

本產品規格書規定了由歐品電子有限公司設計生產的1.27mm SMC Connector SMT TYPE 型連接器產品的特性及測試方法。本產品規格書適用於但不局限於封面所顯示的產品料號。

2. REFERENCE DOCUMENTS 參考文件

| | | |
|--------------|--|-----------|
| MIL-STD-1344 | Test method for electrical connector | 電子連接器測試方法 |
| MIL-STD-202 | Test method for electrical components | 電子零件測試方法 |
| EIA364 | Test method for electrical components | 電子零件測試方法 |
| JIS C 0051 | Test method for electrical components | 電子零件測試方法 |
| MIL-G-45204C | Specification for gold plating | 鍍金規格 |
| IEC-512-3 | IEC standard for current carrying capacity tests | IEC電流測試標準 |
| QQ-N-290A | Specification for nickel plating | 鍍鎳規格 |
| MIL-P-81728A | Specification for tin/lead plating | 鍍錫鉛規格 |
| MIL-T-10727B | Specification for tin plating | 鍍錫規格 |
| UL1977 | UL standard for safety of attachment plug and receptacle | UL安規要求標準 |

3. FEATURE & DIMENSIONS 特征及尺寸

3.1. PRODUCT DIMENSION 產品尺寸

These connectors shall have the dimensions as shown in drawing.

本產品的相關尺寸參見圖面。

3.2.MALE AND FEMALE PRODUCT 公母產品裝配

3.2.1. Perpendicular to engaging direction垂直插入方向

the design of the centering and guiding in the mpc of the free and fixed board connector modules shall accept a misalignment of 0.41MM in transverse and 0.41MM in longitudinal axes of the connector

固定板連接器模件的 Mpc 裡，連接器設計中心線橫向可接受 0.41mm 和縱向可接受 0.41mm 的偏差。

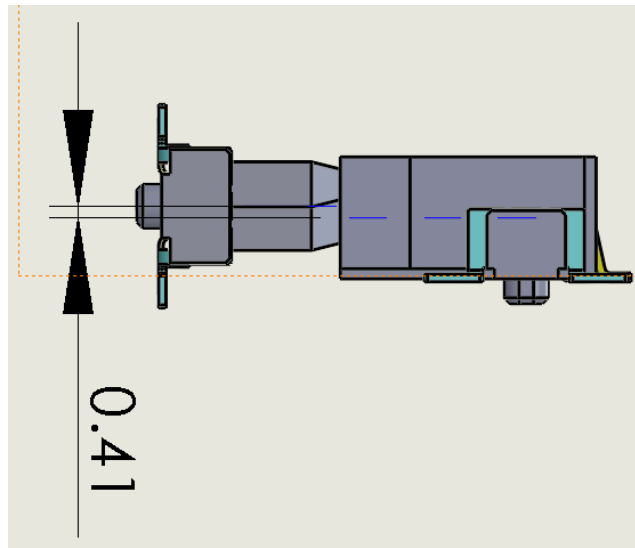

allowed misalignment in transverse axes 在橫向方向允許對插偏差量

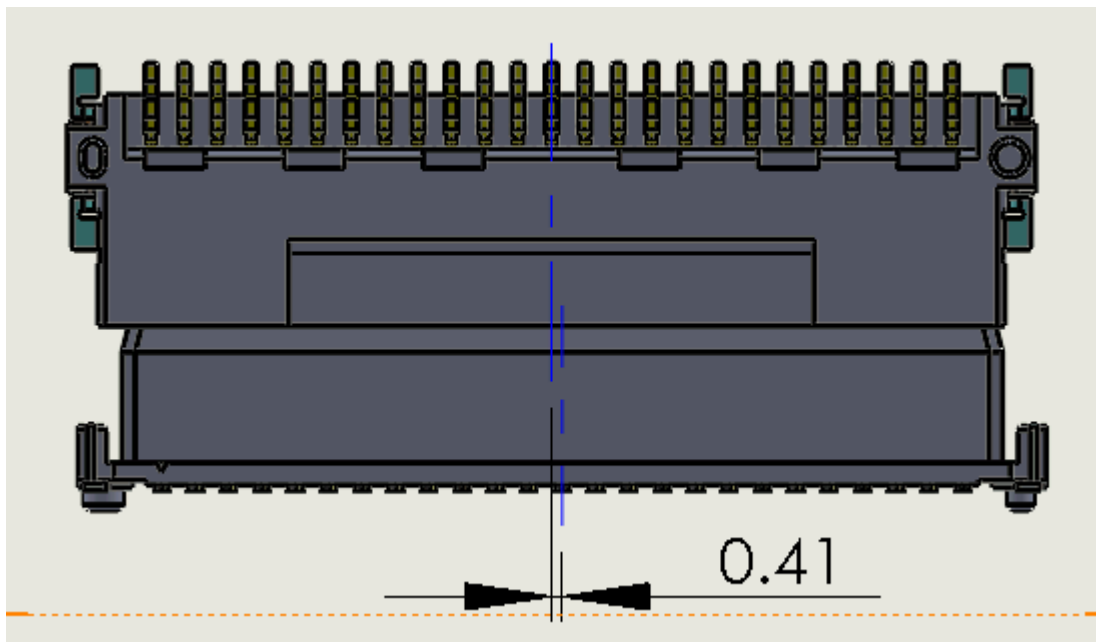

allowed misalignment in longitudinal axes 在縱向方向允許對插偏差量

3.2.2 Inclination 傾向

The center and guiding in the Mpc OF the free and the fixed board connector modules shall allow an initial angular misalignment of 2° Max in the transverse and longitudinal axes

固定板連接器模件的在Mpc裡,連接器可接受橫向和縱向2° 的最大傾斜對插角度。



PRODUCT SPECIFICATION OF Oupin

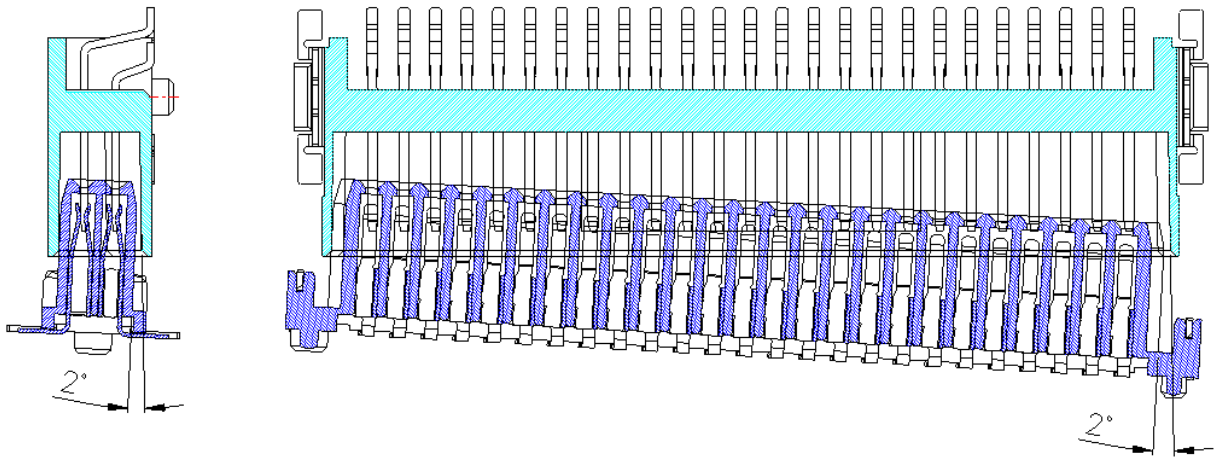

3.2.3 Capability for products wipe length

產品接觸長度等級

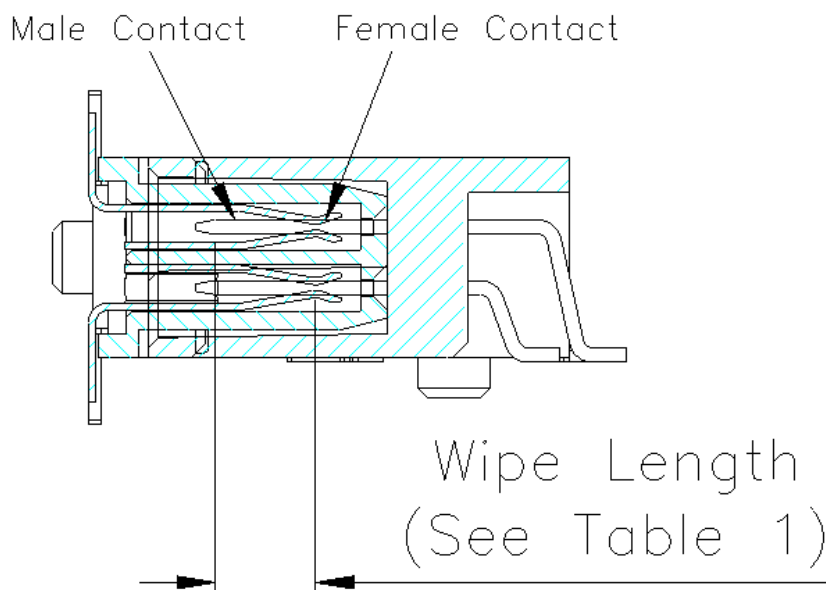

| CONTACT | MATING LEVEL | WIPE LENGTH(MIN) |
|---------|--------------|------------------|
| Pin | 1 | 2.10 |

Table 1

3.3. PCB/PANEL LAYOUT 印刷電路板佈局

The recommended PCB layout is shown in drawing.

本產品適用的 PCB layout 參見圖面。



PRODUCT SPECIFICATION OF Oupin

3.4. BILL OF MATERIAL 材料清單

Harmful material controlling follows the requirements of RoHS. The bill of material is described in drawing.

有害物質控制符合RoHS指令要求。本產品使用的材料參見圖面。

3.5. MECHANICAL & ELECTRICAL CHARACTERISTIC 機械及電氣特性

The connector shall have the mechanical and electrical performance as described in drawing.

本產品的機械及電氣特性參見圖面。

3.6. PACKAGING 包裝

Products shall be packaged according to requirements specified in purchase order for safe delivery, connector container and the packaging method are shown in package specification.

產品可依客戶指定要求包裝，包裝材料與包裝方式參見產品包裝規範。

3.7 RATING CURRENT AND RATING VOLTAGE 額定電流與額定電壓

Rating current: Signal pin 1.7A

額定電流: Signal pin 1.7A

Rating voltage: Signal pin 100V

額定電壓: Signal pin 100V

3.8 STORAGE AND OPERATING TEMPERATURE 存貯與使用溫度

Temperature range: $-55^{\circ}\text{C} \sim +125^{\circ}\text{C}$., including terminal temperature rise for rating current.

Storage Temperature : $0^{\circ}\text{C} \sim +40^{\circ}\text{C}$, Humidity: 80%RH under , Time limit is 12 months the products are stored .

溫度範圍： $-55^{\circ}\text{C} \sim +125^{\circ}\text{C}$,包含接觸端子的額定電流溫升.

儲存溫度： $0^{\circ}\text{C} \sim +40^{\circ}\text{C}$ ，濕度：80%RH以下,產品限存時間為12個月.

4.Environmental 環境要求

4.1. SOLDERABILITY 可焊性

Connectors meet solder-ability to EIA-364-52, and shall be free of contaminants.

產品可焊性符合EIA-364-52標準規定的相關要求，表面不得有污染物。

4.2. RESISTANCE TO SOLDER HEAT 耐焊接熱

4.2.1. INFRARED REFLOW 紅外線回流焊接

Each cycle consists of three consecutive phases, as shown in **Table III**.

每個焊接週期包括三個連續的階段，見附表三。

Note: 說明



PRODUCT SPECIFICATION OF Oupiin

Device temperature measurements are referenced from the top-center of the package outer surface.

設備溫度量測時以從頂部中間位置測量為準。

5. PERFORMANCE AND TEST DESCRIPTION 性能及測試

5.1. REQUIREMENT 要求

Product is designed to meet electrical, mechanical, and environmental performance requirements specified in **Table I**.

本產品設計符合附表一所列的機械，電氣及環境要求。

5.2. TEST CONDITION 測試條件

Unless otherwise specified, all tests shall be performed at ambient environmental conditions.

除非特別注明，所有測試在室溫條件下完成。

5.3. SAMPLE SELECTION 樣品選擇

Test samples shall be selected at random from current production. No test samples shall be reused. Samples are pre-conditioned with 10cycles of durability. Each group shall be containing 5 test samples at least.

測試樣品從現生產的產品中隨機抽取，所有測試過的樣品不得重複使用。樣品已預先插拔10次，每組測試至少有5個樣品。

5.4. TEST SEQUENCE 測試順序

Product qualification test sequence as shown in **Table II**.

產品品質測試順序見附表二。



PRODUCT SPECIFICATION OF Oupin

Table I: Test Requirements and Methods

附表一：測試要求與方法

| Items 項目 | Requirements 要求 | Test Methods 測試方法 |
|--|--|--|
| 1. Confirmation of Product 產品確認 | Product shall be conforming to the requirements of applicable product drawing. 產品必須符合相關產品圖面的要求。 | Visually, dimensions and functionally inspected per applicable product drawing. 依相關產品圖面，檢查產品的外觀、尺寸及功能。 |
| 2. Contact Resistance 接觸阻抗 | Signal pin: 25 mΩ Max. initial. Contact resistance change Δ 10 mΩ Max Signal pin 初始狀態 25mΩ Max, 接觸電阻變化值 Δ 10 mΩ Max | Subject mated contacts assembled in housing to closed circuit of 100 mA max. 20mV max. 所述固定端子連結到一個封閉回路中測試，電流 100 mA max, 電壓 20 mV max。 |
| | Per EIA-364-23 適用：EIA-364-23 | |
| 3. Insulation Resistance 絕緣阻抗 | 1000 MΩ Min. 最小 1000 MΩ. | Measure by applying test potential between the adjacent contacts, and between the contacts and ground in the mated connector. (500 V DC \pm 10%). 測試產品相鄰端子間以及端子與接地間的電阻 (500 V DC \pm 10%)。 |
| | Per EIA-364-21 適用：EIA-364-21 | |
| 4. Dielectric Withstanding Voltage 耐電壓 | Signal pin must withstand test potential of 500 VDC RMS for 1 minute, No braekdown. Signal pin 必須承受測試電 500VDC RMS， 時間 1 分鐘，无瞬斷。 | Measure by applying test potential between the adjacent contacts, and between the contacts and ground in the mated connector. 對產品相鄰端子間以及端子與接地間加載電壓，測試其漏電流。 |
| | Per EIA-364-20-Method B 適用：EIA-364-20, 方法 B | |
| 5. Durability (Repeated Mating/Un-mating) 耐久性 | After testing, no damage, Dielectric Strength should be OK; signal contact resistanc change 10mΩ max. 測試後產品無損壞，耐電壓測試 ok， 信號針接觸阻抗比初始值增大不超過 10 mΩ。 | Repeat mate and unmated for connector 500 cycles, at a speed of 5cycle / minute Max. 重復進行配合產品 500 次插拔， 最大速度 5 次/分鐘。 |



PRODUCT SPECIFICATION OF Oupin

| | | |
|---|--|--|
| | Per EIA-364-09 適用：EIA-364-09 | |
| 6. Retention Force 保持力 | Signal pin and Lock: 2N/Pin. Min. Signal pin 和 Lock 每支最小 2N | Apply axial pull out force at a speed of 25.4±3 mm/minute on the contact assembled in the housing. 以 25.4±3mm/分鐘的速度施加軸向拉力從塑膠本體上拔出端子。 |
| | Per EIA-364-29 適用：EIA-364-29 | |
| 7. Mating /Un-mating Force 插入力/拔出力 | Signal: Mating force:0.8N /pin Max Un-mating force:0.15N/pin Min. Signal 每 Pin 插入力最大:0.8N 每 Pin 拔出力最小：0.15N | At a speed of 25.4±3 mm/minute, apply axial insert the mating part into fully or pull out from the subject product. 以 25.4±3 mm/分鐘的速度，軸向完全插入對配插件到被測產品中或從被測產品中拔出。 |
| | Per EIA-364-13 適用：EIA-364-13 | |
| 8. Vibration Sinusoidal Low Frequency 低頻正弦振動 | After testing, no damage, No electrical discontinuity greater Than 0.1µs shall occur, signal contact resistanc change 10mΩmax. Dielectric Strength should be OK. 測試後產品無損壞，不允許出現超過 0.1 µs 的瞬間斷開，測試後信號針接觸阻抗初始值增大不超 10 mΩ。 耐電壓測試 ok。 | Subject mated connector to 10-2000-10 Hz traversed in 20 minute at 196.1m/s ² (20gn) peak amplitude,, 2 hours each of 3 mutually perpendicular planes. 10-2000-10 振幅 196.1m/s ² 條件下，在互相垂直的三個面上，每個面 2 小時下測量。 |
| | Per EIA-364-28 適用：EIA-364-28 | |
| 9. Thermal Shock 冷熱沖擊 | After testing, no damage, Dielectric Strength should be OK; signal contact resistance change 10 mΩ max. 測試後產品無損壞，耐電壓測試 ok。 信號針接觸阻抗比初始值增大不超過 10 mΩ。 | Temperature range from -55°C to +125°C. Start from -55°C, after 30 minutes, change to +125°C; change time is no more than 5 minutes, total 10 cycles. 溫度變化範圍： -55°C~ +125°C。從 -55°C 開始，30 分鐘後換到+125°C，轉換時間不超過 5 分鐘，共 10 個循環。 |
| | Per EIA-364-32 適用：EIA-364-32 | |



PRODUCT SPECIFICATION OF Oupin

| | | |
|---|---|--|
| <p>10. Humidity-Temperature Cycle 溫濕度循環</p> | <p>After testing, no damage, Dielectric Strength should be OK; signal contact resistance change 10 mΩ max. 測試後產品無損壞，耐電壓測試 ok。 信號針接觸阻抗比初始值增大不超過 10 mΩ。</p> <p>Per EIA-364-31 適用：EIA-364-31</p> | <p>Subject product to 40±2°C, 90~95%.R.H , Duration 96hours 產品置於 40±2°C,相對濕度：90~95%, 持續 96 小時。</p> |
| <p>11. Salt Spray 鹽霧</p> | <p>After testing, no damage, Dielectric Strength should be OK; signal contact resistance change 10 mΩ max. 測試後產品無損壞，耐電壓測試 ok。 信號針接觸阻抗增大不超過 10 mΩ。</p> <p>Per EIA-364-26 適用：EIA-364-26</p> | <p>5±1% salt concentration 24hours 35±2°C 鹽水濃度 5±1%，時間 24 小時，溫度 35±2°C。</p> |
| <p>12. High Temperature Life 高溫老化</p> | <p>After testing, no damage, Dielectric Strength should be OK; signal contact resistance change 10 mΩ max. 測試後產品無損壞，耐電壓測試 ok。 信號針接觸阻抗比初始值增大不超過 10 mΩ。</p> <p>Per EIA-364-17 適用：EIA-364-17</p> | <p>Subject product to 125±2°C for 96hours continuously. 產品置於 125±2°C 連續 96 小時。</p> |
| <p>13. Solderability 可焊性</p> | <p>There shall have a solder coverage of 95% minimum. 產品在測試完成後，焊接部位粘錫面積大於 95%。</p> <p>Per EIA-364-52 適用：EIA-364-52</p> | <p>Soldering time: 5seconds. Temperature: 245±5°C. 焊接時間：5 秒。 溫度：245±5°C。</p> |



PRODUCT SPECIFICATION OF Oupin

Table II: Product Qualification Test Sequence

附表二：產品測試順序

| Test Description 測試描述 | Test Group 測試分組 | | | | | | | | | |
|---|-----------------|---|-----|-----|-----|-----|-----|-----|---|--|
| | A | B | C | D | E | F | G | H | | |
| 1. Conformation of Product 產品確認 | 1,7 | 1 | 1,9 | 1,9 | 1,9 | 1,9 | 1,9 | 1,9 | 1 | |
| 2. Contact Resistance 接觸阻抗 | 2,6 | | 2,6 | 2,6 | 2,6 | 2,6 | 2,6 | 2,6 | | |
| 3. Insulation Resistance 絕緣阻抗 | 3 | | 3,7 | 3,7 | 3,7 | 3,7 | 3,7 | 3,7 | | |
| 4. Dielectric Withstanding Voltage 耐電壓 | 4 | | 4,8 | 4,8 | 4,8 | 4,8 | 4,8 | 4,8 | | |
| 5. Durability 耐久性 | 5 | | | | | | | | | |
| 6. Contact Retention Force 端子保持力 | | 3 | | | | | | | | |
| 7. Mating/Un-mating Force 插入/拔出力 | | 2 | | | | | | | | |
| 8. Vibration Sinusoidal Low Frequency 低頻正弦振動 | | | 5 | | | | | | | |
| 9. Thermal Shock 冷熱沖擊 | | | | 5 | | | | | | |
| 10. Humidity-Temperature Cycle 溫濕度循環 | | | | | 5 | | | | | |
| 11. Salt Spray 鹽霧 | | | | | | 5 | | | | |
| 12. High Temperature Life 高溫老化 | | | | | | | 5 | | | |
| 13. Solder-ability 可焊性 | | | | | | | | | 2 | |

Table III : Reflow Soldering Profile

附表三：回流焊接曲線圖

Lead-free reflow profile requirements:

無鉛回流焊接曲線



PRODUCT SPECIFICATION OF Oupin

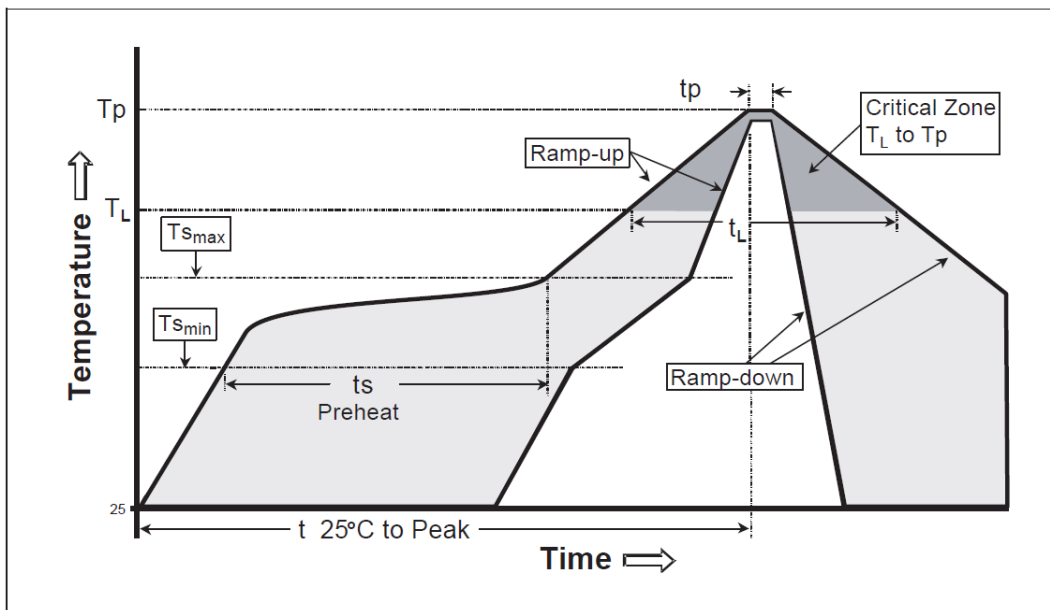

This profile is the minimum requirement for evaluating soldering heat resistance of components. Heat transfer method used for reflow soldering is hot air convection. The actual air temperatures used to achieve the specified profile largely dependent on the reflow equipment.

這個曲線圖是評估元件器件焊接抗熱的基本要求。應用在對焊接中的熱傳遞方式是熱氣對流。達到特定曲線圖地實際溫度主要依賴與回流焊接設備。